



DT3 Series Temperature Controller Instruction Sheet

■ Precaution



DANGER! Caution! Electric Shock!

1. Do not touch the AC terminals while the power is supplied to the controller to prevent an electric shock.
2. Make sure power is disconnected while checking the unit inside.



WARNING!

This controller is an open-type temperature controller. Make sure to evaluate any dangerous application in which a serious human injury or serious property damage may occur.

1. Always use recommended solder-less terminals: Fork terminal with isolation. (M3 screw, width is 6.0mm)
2. Do not allow dust or foreign objects to fall inside the controller to prevent it from malfunctioning.
3. Never modify or disassemble the controller.
4. Do not connect anything to the "No used" terminals.
5. Make sure all wires are connected to the correct polarity of terminals.
6. Do not install and/or use the controller in places subject to:
 - Dust or corrosive gases and liquid
 - High humidity and high radiation
 - Vibration and shock
 - High voltage and high frequency
7. Must turn power off when wiring and changing a temperature sensor.
8. Be sure to use compensating wires that match the thermocouple types when extending or connecting the thermocouple wires.
9. Please use wires with resistance when extending or connecting a platinum resistance thermometer (RTD).
10. Please keep the wire as short as possible when wiring a platinum resistance thermometer (RTD) to the controller and please route power wires as far as possible from load wires to prevent interference and induced noise.
11. This controller is an open-type unit and must be placed in an enclosure away from high temperature, humidity, dripping water, corrosive materials, airborne dust and electric shock or vibration.
12. Please make sure power cables and signals from instruments are all installed properly before energizing the controller, otherwise serious damage may occur.
13. Please do not touch the terminals in the controller or try to repair the controller when power is applied to prevent an electric shock.
14. Wait at least one minute after power is disconnected to allow capacitors to discharge, and please do not touch any internal circuit within this period.
15. Do not use acid or alkaline liquids for cleaning. Please use a soft, dry cloth to clean the controller.

■ Display, LED & Pushbuttons



- PV: Present value
- SV: Set value
- °C, °F: Celsius or Fahrenheit LED
- ALM1~ALM3: Alarm output LED
- AT: Auto-tuning LED
- MAN: Manual mode LED
- OUT1/OUT2: Output LED
- REMOTE: Remote control LED
- EV: EVENT LED
- F1 F2 : Self-defined function keys
- ◀ SET : "Select" and "set up" keys
- ▼ ▲ : Set value tuning keys

■ Oding Information

DT3 1 2 3 4 - 5 6 7 8

DT3 Series	DT3: Delta 3 Series Temperature Controller	
1 2 Panel Size (W×H)	20: 4848 1/16 DIN W48 × H48mm 30: 7272 W72 × H72mm	40: 4896 1/8 DIN W48 × H96mm 60: 9696 1/4 DIN W96 × H96mm
3 1st output group selection	R: Relay Output, 250 VAC, 5A V: Voltage Pulse Output, 12V -10%~+20% C: DC Current Output, 4 ~ 20 mA L: Linear Voltage Ouptut 0 ~ 10 VDC	
4 Power supply	A: AC 80 ~ 260 V D: DC 24 VDC	

5 2nd output group selection	0: None R: Relay Output, 250 VAC, 5A V: Voltage Pulse Output, 12V -10%~+20% C: DC Current Output 4 ~ 20 mA L: Linear Voltage Output 0 ~ 10 VDC
6 EVENT inputs/ CT function (optional) 1	0: None, 1: Event Input3, 2: RS-485 Communication
7 EVENT inputs/ CT function (optional) 2	0: None, 1: Event Input2, 2: CT measure input2, 3: Retransmission Output
8 EVENT inputs/ CT function (optional) 3	0: None, 1: Event Input1, 2: CT measure input1, 3: Remote Setpoint input

■ Specifications

Input Voltage	AC 80 ~ 260 V, 50/60Hz; DC 24 VDC ±10%
Power Consumption	5VA max.
Display Method	LCD display. Process value (PV): Yellow color, Set point (SV): Green color
Sensor Type	Thermocouple: K, J, T, E, N, R, S, B, L, U, TXK
	3-wire Platinum RTD: Pt100, JPt100
	Resistance: Cu50, Ni120
	Analog input: 0 ~ 5 V, 0 ~ 10 V, 0 ~ 20 mA, 4 ~ 20 mA, 0 ~ 50 mV
Control Mode	PID, PID program control (Ramp/Soak control), FUZZY, Self-tuning, Manual and On/FF
Control Output	Relay output: Max. load 250VAC, 5A resistive load
	Voltage pulse output: DC 12V, Max. output current 40mA
	Current output: DC 4 ~ 20mA output (Load resistance: Max. 500Ω)
	Analog voltage output: 0 ~ 10V
Alarm Output Type	Relay output: Max. load 250VAC, 5A resistive load
Display Accuracy	0 or 1 digit to the right of the decimal point (selectable)
Sampling Rate	Analog input: 0.1 sec/ per scan; Thermocouple or Platinum RTD: 0.1 sec/per scan
Vibration Resistance	10 to 55Hz, 10m/s ² for 10min, each in X, Y and Z directions
Shock Resistance	Max. 300m/s ² , 3 times in each 3 axes, 6 directions
Ambient Temperature	0°C ~ +50°C
Storage Temperature	-20°C ~ +65°C
Altitude	Max. 2000m
Relative Humidity	35% ~ 80% RH (non-condensing)

■ Operation

- ❖ There are three modes of operation: operation, regulation and initial setting. When power is applied, controller gets into the operation mode. Press the **SET** key to switch to regulation mode. If the **SET** key is pressed for more than 3 seconds, controller will switch to the initial setting mode. Pressing the **SET** key while in the regulation mode or initial setting mode, forces the controller to return to the operation mode..
- ❖ PV/SV: Sets the temperature set point and displays the temperature process value. Use **▼ ▲** keys to set the temperature set point.
- ❖ Setting method: While in any function mode, press the **◀** key to select the desired function and use **▼ ▲** keys to change settings. Press **SET** key to save the changes.
- ❖ The flow chart below shows how to switch the settings and internal functions:



【Operation Mode】Parameter Setting:

Display	Description	Factory Setting
1234	Use ▼ ▲ to set temperature set point, use ◀ to switch between the display parameter	
R-S	RUN/STOP: Control setting RUN or STOP	RUN
PLRN	PATTERN: Start pattern setting (set control mode to PROG mode)	0
SLEP	STEP: Start step setting (set control mode to PROG mode)	0

SP	SELECT POINT: Decimal point setting (0: integral ; 1: one decimal point)	1
LoL	LOCK: Setting lock mode (LOCK1: all; LOCK2: onlySV and F1/F2 key is allowed)	OFF
AL H	ALARM1 HIGH: Upper limit alarm 1 (display according to the setting in ALARM mode)	4.0
AL L	ALARM1 LOW: Lower limit alarm 1 (display according to the setting in ALARM mode)	4.0
AL2H	ALARM2 HIGH: Upper limit alarm 2 (display according to the setting in ALARM mode)	4.0
AL2L	ALARM2 LOW: Lower limit alarm 2 (display according to the setting in ALARM mode)	4.0
AL3H	ALARM3 HIGH: Upper limit alarm 3 (set OUT2 to ALARM mode and it will display according to the setting in ALARM mode)	4.0
AL3L	ALARM3 LOW: Lower limit alarm 3 (set OUT2 to ALARM mode and it will display according to the setting in ALARM mode)	4.0
A1HP	ALARM1 HIGH PEAK: High peak value 1	
A1LP	ALARM1 LOW PEAK: Low peak value 1	
A2HP	ALARM2 HIGH PEAK: High peak value 2	
A2LP	ALARM2 LOW PEAK: Low peak value 2	
A3HP	ALARM3 HIGH PEAK: High peak value 3 (display when OUT2 is set to alarm mode)	
A3LP	ALARM3 LOW PEAK: Low peak value 3 (display when OUT2 is set to alarm mode)	
OUT1	OUT1: Display and adjust output value of 1 st output group	0.0
OUT2	OUT2: Display and adjust output value of 2 nd output group (display when OUT2 is set to Heating/Cooling Mode)	0.0
OUT1M	OUT1 MAX: Upper limit % of 1 st output group (perform linear calculation again)	100.0
OUT1L	OUT1 MIN.: Lower limit % of 1 st output group	0.0
OUT2M	OUT2 MAX: Upper limit % of 2 nd output group (display when OUT2 is set to Heating/Cooling Mode)	100.0
OUT2L	OUT2 MIN: Lower limit % of 2 nd output group (display when OUT2 is set to Heating/Cooling Mode)	0.0
CT1	CT1: Display CT1 current (display when external CT is connected to CT1)	
CT2	CT2: Display CT2 current (display when external CT is connected to CT2)	
	press ◀ to return to target temperature setting.	

【Initial Setting Mode】 Parameter Settings:

Display	Description	Factory Setting
INPT	INPUT: Set input type (refer to "Temperature Sensor Type & Temperature Range Chart" for the selection of Thermocouple or Platinum Resistance types.)	PT
TEMP	TEMP. UNIT: Set temperature unit °C/°F (it will not be displayed when in analog input mode)	°C
EP-H	TEMP. HIGH: Set up upper temperature limit (the upper limit setting is different for different types of sensor)	850.0
EP-L	TEMP. LOW: Set up lower temperature limit (the lower limit setting is different for different types of sensor)	-200.0
CTRL	CONTROL: Select control modes (5 different modes: ON-OFF, PID, MANUAL, FUZZY and 2PID)	PID
CTRS	CONTROL SV provides 4 different options: CONS; PROG; SLOP; and REMO. REMO mode is available when REMOTE function is added.	CONS
WTSV	WAIT SV: Set up waiting temperature (display when in programmable control)	
W-TM	WAIT TIME: Set up waiting time (display when in programmable control)	
SLOP	SLOP: Set up start slope (display when in programmable control)	
PATM	PATTERN: Select pattern to be edited (display when in programmable control, there are 16 patterns and each pattern includes 16 steps. Setting parameters are OFF, SAVE, 0~F.)	OFF
TUNE	TUNE: Select AT or ST (display when in PID/2PID control mode)	AT
S-HC	SELECT HEAT/COOL: Select heating, cooling or dual output heating and cooling	H1H2
AL1	ALARM1 SET: Set up Alarm 1 mode (refer to "Alarm Output" for more setting on modes)	0
AL1o	ALARM1 OPTION: Set up Alarm 1 options (refer to "Alarm Output" for more setting on modes)	0
AL1d	ALARM1 DELAY: Set up Alarm 1 delay (refer to "Alarm Output" for more setting on modes)	0
AL2	ALARM2 SET: Set up Alarm 2 mode (refer to "Alarm Outputs")	0
AL2o	ALARM2 OPTION: Set up Alarm 2 options (refer to "Alarm Outputs")	0

AL2d	ALARM2 DELAY: Set up Alarm 2 delay (refer to "Alarm Outputs")	0
AL3d	ALARM3 SET: Set up Alarm 3 mode (refer to "Alarm Output")(display when OUT2 is set to ALARM mode)	0
AL3o	ALARM3 OPTION: Set up Alarm 3 options (refer to "Alarm Output") (display when OUT2 is set to ALARM mode)	0
AL3d	ALARM3 DELAY: Set up Alarm 3 delay (refer to "Alarm Outputs") (display when OUT2 is set to ALARM mode)	0
PVCL	PV Color Change Function: Select the alarm to change PV display color. (refer to "Alarm Outputs")	OFF
PdSW	2PID change temperature (display on 2PID control mode)	1.0
PdRE	2PID reset temperature (display on 2PID control mode)	0.5
RMLP	REMOTE TYPE: Set up Remote type (display when CLRS is set to REMO mode) (V0:0~5V; V1:1~5V; V10:0~10V; MA0:0~20mA; MA4:4~20mA)	MA4
EXE1	Select auxiliary function 1	0
EXE2	Select auxiliary function 2	0
CoSH	COMMUNICATION WRITE: Enable/disable communication write-in	OFF
C-SL	COMMUNICATION SELECT: Select ASCII or RTU format	ASCII
C-No	COMMUNICATION NO.: Set up communication address	1
bPS	BPS: Set up baudrate	9600
LEN	LENGTH: Set up data length	7
StoP	STOP: Set up stop bit	1
PRLY	PARITY: Set up parity bit	E

Press **◀** to return to input type setting

【Regulation Mode】 Parameter Settings:

Display	Description	Factory Setting
AL	AT: Auto-tuning Switch (display when setting Ctrl = PID/FUZZY/2PID, TUNE = AT, R-S=RUN) Press ◀ ▽	OFF
St	ST: SELF-TUNING Switch (display when setting Ctrl = PID, TUNE = ST)	OFF
PLd	PID NO.: Select the n th (n=0~5) PID. When set in AUTO, PID is auto-selected. (display when setting Ctrl=PID)	0
SV0 ~ SV5	PID SV NO.: According to the selection of PID No. (n=0~5), set SV value accordingly. It will allow the system perform auto selection when it's set to AUTO mode. (Display when Ctrl = PID/FUZZY/2PID).	100
P0 ~ P5	P : Proportional Setting (display when setting Ctrl = PID/FUZZY/2PID and TUNE = AT) Set P value according to the selection of PID No. (n=0~5). When P is set to AUTO, the system will select P value accordingly.	47.6
I0 ~ I5	I: Integral Time Setting (display when Ctrl=PID/FUZZY/2PID; this parameter is set automatically when TUNE=AT.) Set I value according to the selection of PID No. (n=0~5). When I is set to AUTO, the system will select I value accordingly.	260
d0 ~ d5	D: Deviation Time SETting: (display when Ctrl=PID/FUZZY/2PID; this parameter is set automatically when TUNE=AT.) Set D value according to the selection of PID No. (n=0~5). When D is set to AUTO, the system will select D value accordingly.	41
IoF0 ~ IoF5	I OFFSET: Integral deviation setting, when Integral is not 0. (display when Ctrl=PID/FUZZY/2PID; this parameter is set automatically when TUNE=AT.) Set IOF value according to the selection of PID No. (n=0~5). When IOF is set to AUTO, the system will select IOF value accordingly.	0
PdoF	PD OFFSET: PD offset when Integral=0 to eliminate a consistent deviation.	0
FZ-R	Set up Fuzzy gain value (when Ctrl=FUZZY)	4
FZdb	Set up Fuzzy Deadband (when Ctrl=FUZZY)	0
o1-S	OUT1 HYSTERESIS: Adjust Output 1 hysteresis (when in ON/OFF control)	0
o2-S	OUT2 HYSTERESIS: Adjust Output 2 hysteresis (when in ON/OFF control)	0
o1-H	OUT1 HEAT: Heating control cycle for Output 1 (when Ctrl= PID/FUZZY/MANUAL/2PID)	Output selection: C; V; S: 5sec. R: 20sec.
o1-L	OUT1 COOL: Cooling control cycle for Output 1 (when Ctrl= PID/FUZZY/MANUAL/2PID)	
o2-H	OUT2 HEAT: Heating control cycle for Output 2 (when Ctrl= PID/FUZZY/MANUAL/2PID)	
o2-L	OUT2 COOL: Cooling control cycle for Output 2 (when Ctrl= PID/FUZZY/MANUAL/2PID)	

COEF	COEF: Ratio of Output 1 against Output 2 (when Ctrl= PID/FUZZY/2PID and when in dual output control)	1.00
DEAD	DEAD: Set up deadband (when Ctrl is not set to MANUAL and when in dual output)	0
PV-F	PV FILTER: Set up input filter factor of PV	1
PV-R	PV RANGE: Set up input filter range of PV	1.00
PV OF	PV OFFSET: Adjust input compensation of PV	0.0
PV GA	PV GAIN: Adjust input gain of PV	0.000
SVSL	SV SLOPE: Set up rising slope (when CRTS = SLOP)	
A1MA	ANALOG OUT1 MAX.: Adjust upper limit compensation for analog Output 1 (1scale = 1μA; 1scale = 1mV)	0
A1ML	ANALOG OUT1 MIN.: Adjust lower limit compensation for analog Output 1 (1 scale = 1μA; 1scale = 1mV)	0
A2MA	ANALOG OUT2 MAX.: Adjust upper limit compensation for analog Output 2 (1scale = 1μA; 1scale = 1mV)	0
A2ML	ANALOG OUT2 MIN.: Adjust lower limit compensation for analog Output 2 (1scale = 1μA; 1scale = 1mV)	0
REMA	RETRANSMISSION MAX.: Adjust upper limit compensation for Retransmission (1scale = 1μA) (display when a Retransmission Card is connected to DT3)	0
REML	RETRANSMISSION MIN.: Adjust lower limit compensation for Retransmission (1scale = 1μA) (display when a Retransmission Card is connected to DT3)	0
RM-B	REMOTE GAIN: Adjust Remote gain (When CRTS = REMO)	0
RM-F	REMOTE GAIN: Adjust Remote compensation (When CRTS = REMO)	0
RM-L	REMOTE LOW: Remote lower limit (When CRTS=REMO)	0
RM-H	REMOTE HIGH: Remote higher limit (When CRTS=REMO)	100
EVE1	EVENT1: Set up EVENT1 function (display when a Event Card is connected to EVENT1)	OFF
EVE2	EVENT2: Set up EVENT2 function (display when a Event Card is connected to EVENT2)	OFF
EVE3	EVENT3: Set up EVENT3 function (display when a Event Card is connected to EVENT3)	OFF

PID mode: Any of the 6 PID groups can be selected. When set to AUTO mode, the program will automatically select the PID group that is the closest to the target temperature.

Select 0~5 group of PID and execute AT function, the system will automatically load P; I; D and IOF parameters into the selected PID group.

PLD Select the n th PID (n = 0 ~ 5)	press ◀ to set 0 ~ 5 th PID parameters	
SP0 Set up the 0 th PID temperature value press ◀ ▾	SP1 ~ SP4	SP5 Set up the 5 th PID temperature value press ◀ ▾
PD Set up the 0 th proportional band value	P1 ~ P4	P5 Set up the 5 th proportional band value
LD Set up the 0 th Ti value	L1 ~ L4	L5 Set up the 5 th Ti value
DD Set up the 0 th Td value	D1 ~ D4	D5 Set up the 5 th Td value
LOFD Set up the 0 th PID integral deviation Press ◀ to set the parameters in "Regulation Mode"	LOF1 ~ LOF4	LOF5 Set up the 5 th PID integral deviation Press ◀ to set the parameters in "Regulation Mode"

Programmable Editing: set **LERL** to **PLD** or **FUZZ** and set **LEAS** to **PROG**.

PERN Select desired editing pattern number 0~F	press ◀ to set the desired editing pattern number 0~F	
If the setting is OFF, leave the editing pattern page and go to EUNE to continue with the setting.		
SP00 Edit the temperature of step No.0 of pattern No. 0 press ◀ ▾	SP10 ~	SPF0 Edit the temperature of step No.0 of pattern No. 15
EL00 Edit the time of step No.0 of pattern No. 0 (time unit: hh, mm)	EL10 ~	ELF0 Edit the time of step No.0 of pattern No.15 (time unit: hh, mm)
SP01 ~ EL0E Set up step 0~15 in order	SP11 ~	SPF1
SP0F Edit the temperature of step No.15 of pattern No.0	SP1F ~	SPFF Edit the temperature of step No.15 of pattern No.15
EL0F Edit the time of step No.15 of pattern No.0	EL1F ~	ELFF Edit the time of step No.15 of pattern No.15
PSY0 Select the actual required steps for executing pattern No.0	PSY1 ~	PSYF Select the actual required steps for executing pattern No.15

LYC0 Set up the additional cycle (0~199) for pattern No. 0 execution	LYC1 ~ LYC15 Set up the additional cycle (0~199) for pattern No. 15 execution
LN0 Set up the link pattern of pattern No.0 (0~F; END; STOP) Press ◀ to return to the selection of desire editing pattern and number.	LN15 Set up the link pattern of pattern No.15 (0~F; END; STOP) Press ◀ to return to the selection of desire editing pattern and number.

■ Initial Start-up Setting

- When setting up DT3 for the first time, press **SET** key for more than 3 seconds till the screen display **LNPE** and select according to your temperature sensor type. Please be aware that a selection of wrong model would cause PV temperature display error. (Refer to the chart below)
- When setting up the temperature sensor type by using RS-485, write your value (range 0~19) into register 1004H.
- When setting up the current input method, remove the temperature controller cover and set JP8 to short. (Refer to the chart below)

● Temperature Sensor Type & Temperature Range Chart

Input Temperature Sensor Type	Register Value	Temperature Range	Input Temperature Sensor Type	Register Value	Temperature Range
Thermocouple K type	K 0	-200 ~ 1300°C	Thermocouple TXK type	EXK 10	-200 ~ 800°C
Thermocouple J type	J 1	-100 ~ 1200°C	Platinum Resistance (JPt100)	JPE 11	-20 ~ 400°C
Thermocouple T type	T 2	-200 ~ 400°C	Platinum Resistance (Pt100)	PE 12	-200 ~ 850°C
Thermocouple E type	E 3	0 ~ 600°C	Resistance (Ni120)	NZ 13	-80 ~ 300°C
Thermocouple N type	N 4	-200 ~ 1300°C	Resistance (Cu50)	CU 14	-50 ~ 150°C
Thermocouple R type	R 5	0 ~ 1700°C	Analog Voltage Input (0~5V)	V5 15	-999~9999
Thermocouple S type	S 6	0 ~ 1700°C	Analog Voltage Input (0~10V)	V10 16	-999~9999
Thermocouple B type	B 7	100 ~ 1800°C	Analog Voltage Input (0~20m A)	MA0 17	-999~9999
Thermocouple L type	L 8	-200 ~ 850°C	Analog Voltage Input (4~20m A)	MA4 18	-999~9999
Thermocouple U type	U 9	-200 ~ 500°C	Analog Voltage Input (0~50m V)	MV 19	-999~9999

● How to Set Up Current Input

Remove the temperature controller cover and set JP8 to short. JP8 jumper locates near the sensor input area on PCB board.

Normal Input (Factory Setting)

Current Input (4 ~ 20mA, 0 ~ 20mA)



■ Display Unit Setting

Use following parameter to change the PV and SV display unit, select decimal point and switch between °C/F.

- In Operation Mode **SP**: SP=1 displays decimal place (ex: 25.5 degree); SP=0 displays integral number (ex: 25 degree).
- In Initial Setting Mode **EPUM**: Select temperature display unit °C/°F. (°F=°C * 9 / 5 + 32)

■ Set Value and the Upper/Lower Limit of Input Value Setting

- Set the Upper Limit of Input Value: This parameter can be set in the Initial Setting Mode **EP-H**, the upper limit input value must be set within the range shown in the chart "Temperature Sensor Type & Temperature Range".
- Set the Lower Limit of Input Value: This parameter can be set in Initial Setting Mode **EP-L**, the lower limit input value must be set within the range shown in the chart "Temperature Sensor Type & Temperature Range".
- Set the SV: This parameter can be set in Operation Mode, SV value must be set within the range of upper/lower limit input value. SV can not be set in In "Program Mode" or in "Remote Mode".

■ Digital Filter and Linear Compensation Setting

In "Regulation Mode", **PV-F** and **PV-R** parameters can be used to adjust the filter status and to avoid interferences on input signal.

- PV-F**: Filter Factors (setting range=0~50; factory setting=8). Digital Filter Calculation equation: PV=(Last displayed PV * n + Measure Value)/(n+1). When the parameter value is small, the PV display is close to the Measured Value. When the parameter

value is large, the PV response is slow.

- **PV-R**: Filter Range (setting range=0.10~10.00°C/°F). If factory setting = 1, it means the controller will begin Digital Filter Calculation when the Measure Value lies within the range of "Last displayed PV + / - 1.00°C/°F". Therefore, it is recommended to set a larger value when noise interferences is serious.

When PV display value is different than user's expectation, Linear Compensation function can be set by **PVdF** and **PVdR** parameters in "Regulation Mode".

- **PVdF**: Linear Compensation Value (setting range= -99.9 ~ +99.9). Linear Compensation Calculation equation: PV = Measure Value + Compensation Value.
For example: Measure Value=25.0; Compensation = 1.2. After applying to the Compensation equation PV=26.2.
- **PVdR**: Linear Compensation Gain (setting range = -0.999~0.999). Linear Compensation Gain Calculation equation: PV = Measure Value * (1 + Gain/1.000) + Compensation.
For example: Measure Value=25.0; Gain= 0.100. After applying to the Gain calculation equation PV= 25.0 * (1 + 0.100 / 1.000) = 27.5 °

If temperature deviation is the same in every temperature, setting linear compensation value can solve deviation problem. If temperature deviation varies upon different temperatures, calculate the linear deviation error and adjusts the temperature by setting Gain and Compensation value.

■ Applications of Analog Voltage & Current Input

The input range of analog voltage and current are used as the upper/lower limit of the controller's voltage and current setting. When setting up the desire voltage or current, it must lies within the range of upper/lower limit. For example: If the range of analog input voltage is 0~5V, the upper limit setting will be 5000 and lower limit setting will be 0. If the decimal setting is set to 3 decimal place, a input voltage of 2.5V will displays as 2.500. The equation of Display Value = (Upper limit setting of controller- Lower limit setting of controller)*(Input voltage- Analog lower limit)/(Analog upper limit- analog lower limit) + Lower limit setting of controller.

■ Disable the Cold Junction Function

The cold conjunction function of a thermocouple is set to ENABLE, but in some cases, we can set it to DISABLE.

- In Initial Setting Mode, **EXE1** is used to set the first digit (Y) of Yxxx, (when Y=0, Enable; when Y=1, Disable).

■ Analog Output Compensation

When the output mode is set to analog current output (4~20mA) or linear voltage output (0~10V), user's desire output value can be attained by using compensation function. For example, the analog output 1 can be adjusted in **A1mA** and **A1mV** parameters in "Regulation Mode". The output value can be positive or negative (+/-) and it can be changed by pressing the Up/Down key on the temperature controller. The scale of each pressing is an increase or decrease of 1uA and 1mV.

For example: To change the current output range from 4~20mA to 3.9~20.5mA, set **A1mA** to 500 (20.5-20=0.5mA; 0.5mA/1uA= 500). and set **A1mV** to -100 (3.9-4=-0.1mA; -0.1mA/1uA=-100).

- To control the output manually: Set parameter **CEPL** to **MANU** in 【Initial Setting Mode】 .
- To set output to 0%: Set parameter **OUT1** to **00** or **OUT2** to **00** in 【Operation Mode】 .
- To adjust the lower limit of analog output: Input a desire value and check the meter to adjust the analog input value to desire value (For example: 4~20 m A, adjusting analog value will be 20 m A). Set parameter **A1mV** (Output 1) or **A2mV** (Output 2) to your desire value in 【Regulation Mode】 .
- To set output to 100%: Set parameter **OUT1** (Output 1) = **1000** or **OUT2** (Output 2) = **1000** in 【Operation Mode】 .
- To adjust the lower limit of analog output: Input a desire value and adjust the analog input value to your desire value (For example: 4~20 m A, adjusting analog value will be 20 m A). Set **A1mA** (Output 1) or **A2mA** (Output 2) to your desire value in 【Regulation Mode】 .

■ Retransmission and Compensation Adjusting

When the input value changes, the retransmission output will also be changed correspondingly. For example: If retransmission = 4~20mA ; uppler/lower limit = 100.0 ~ 0. Wen the controller reads 0, it outputs 4mA; when the controller reads 100, it outputs 20mA. The value can also be a negative number to generate a negative slope. For negative slope, sets upper/lower limit = 0~100.0. In this case, when the controller reads 0, it outputs 20mA; when the controller reads 100, it outputs 4mA. Refer to the slope diagram below.

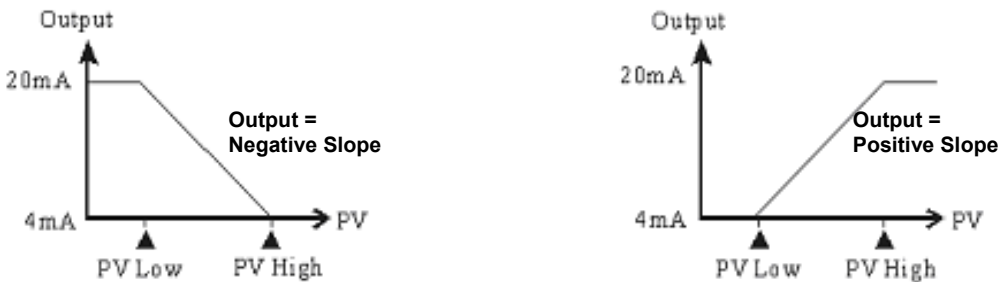

(Figure 1: Proportional Output Diagram)

- To set Retransmission to positive/negative slopes (a Retransmission board must be installed first): In **【Initial Setting Mode】** set the **EXEL** parameter, the last digit (Y) of xxxY indicates when Y=0 positive slope; when Y=1 negative slope.
- To adjust the lower limit of Retransmission:
 - a · Make sure the slope of Retransmission is positive.
 - b · Set lower limit value larger than the display value: In **【Initial Setting Mode】** set the value in **EP-L** larger than the display value (PV).
 - c · Input the analog value to meter, check the meter and adjust the analog input value: In **【Regulation Mode】**, enter the new value into **REML**. For example, if the range is 4~20mA, the new value will be 4mA.
- To adjust the upper limit Retransmission:
 - a · Make sure the slope of Retransmission is positive.
 - b · Set upper limit value smaller than the display value: In **【Initial Setting Mode】** set the value in **EP-H** smaller than the display value (PV).
 - d · Input the analog value to meter, check the meter and adjust the analog input value: In **【Regulation Mode】**, enter the new value into **REMH**. For example, if the range is 4~20mA, the new value will be 4mA.

■ Check the Firmware Version and Output Type

When the temperature controller is ON, the PV and SV display will shows firmware version, output type and accessory functions in first 3 seconds.

- PV (first 3 digits) indicates the firmware version. Ex: 110 indicates firmware version V1.10.
- PV (4th digit) indicates the function of accessory 1.
C: RS485 Communication E: EVENT3 Input
- SV (frist 2 digits) indicates the output type of OUT1 and OUT2.
N: No function V: Voltage pulse output R: Relay output C: Current output
L: Linear voltage output S: SSR output
- SV (3rd digit) indicates the function of accessory 2.
N: No function C: CT measure E: EVENT1 input R: REMOTE input
- SV (4th digit) indicates the function of accessory 3.
N: No function C: CT measure E: EVENT2 input R: RETRANSMISSION output

■ Selection for Heating/Cooling/Alarm/Dual Loop Output Control

DT3 series offers 1 set of Output Control (OUT1) that is built-in internally and 2 sets of Alarm Output(ALARM1 及 ALARM2). User can also purchase a 2nd set of Output Control (OUT2) or a 3rd set of Alarm Output (ALARM3).

- Using 1 set of Output Control :
In **【Initial Setting Mode】** , sets **S-HL** to Heating (H1) or Cooling(C1) mode.
- Using 2nd set of Output Control:
➤ When the 2nd set of output control (OUT2) is used as a 3rd set of arlarm (ALARM3), set **S-HL** to Heating + Alarm 3(H1A2) or Cooling + Alarm 3(C1A2) in **【Initial Setting Mode】** .
OUT2 output types in relay, voltage pulse, analog current, linear voltage and SSR output can all be used for ALARM ON-OFF. For

example, OUT2 is set to analog current output. It outputs 4mA when alarm is OFF and outputs 20mA when alarm is ON.

- When the 2nd set of output control (OUT2) is used as dual output control, set **5-HL** to heating (H1H2); cooling (C1C2); Heating/Cooling(H1C2) or Cooling/Heating (C1H2) control mode in **【Initial Setting Mode】**.

The Dead Band parameter **DEAD** is automatically enabled when the temperature controller is in dual output control. As shown in the diagram follow. The purpose of Dead Band function is to reduce the energy wastage of frequent heating/cooling actions. For example, if SV = 100 degree and **DEAD** = 2.0, there will be no output when the temperature is between 99~101°C..

Output of **DEAD** when in ON-OFF control mode (Ctrl=ON-OFF control):

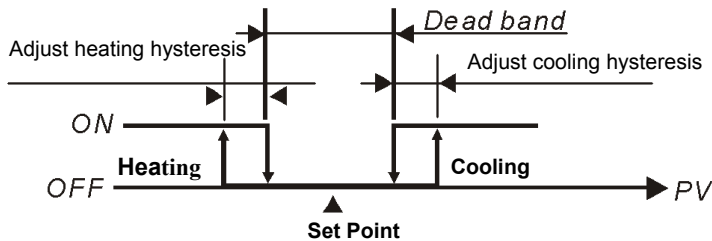

Output of **DEAD** when in PID control mode (Ctrl=PID):

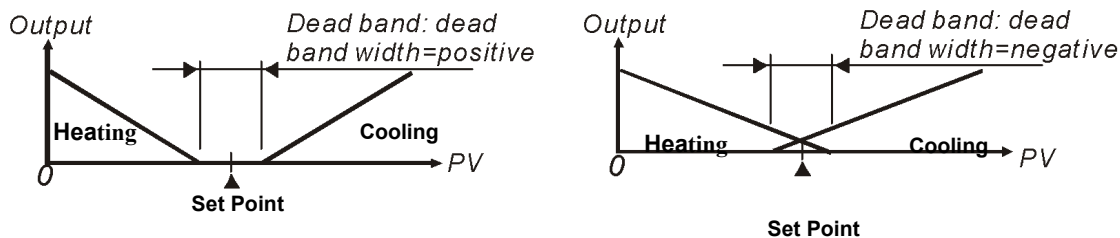

When the controller is in PID control and dual loop output mode, **LoEF** sets the P value of the 2nd set of PID. The 1st set of PID is generated when TUNE= AT, but user can also manually sets the PID value. The P value of th 2nd set of PID = the P value of 1st set of PID x **LoEF**. The I and D value of the 2nd set of PID remains the same as the 1st set of PID.

■ SV Control Mode Setting

There are 4 methods for setting SV of the temperature setting; they are **Fixed, Slope, Program** and **Remote**.

- **Fixed SV Mode:** controls the temperature to directly rise to a fixed setting value
 - Set parameter **LoRS** to **LoNS** in **【Initial Setting Mode】**
 - Set the target temperature: set SV value by a parameter in **【Operation Mode】**
- **Slope SV Mode:** Control temperature rises at a slope (unit: °C/min.) to a fixed value, i.e., the temperature can be set to rise in a set slope (unit: °C/min.). E.G., Set a slope of 0.5 and set SV to 200.0°C; this means the temperature rises 0.5°C every minute from Room Temperature up to 200.0°C.
 - Set parameter **LoRS** to **SLoP** in **【Initial Setting Mode】**
 - Set rising slope (unit: °C/min. or °C/s): set rising slope by parameter **SVSL** in **【Regulation Mode】**
 - Set target temperature: set SV value by a parameter in **【Operation Mode】**
 - Set unit for rising slope (unit: °C/min. or °C/s): for parameter **EXEL** in **【Initial Setting Mode】**, set the corresponding Y position value to xxYx (Y can be 0 or 1; Y=0: °C/min.; Y=1: °C/s).
- **Program SV mode:** This means the temperature setting value is not a fixed value but a setting curve defined by the user according to his-her requirements. By way of PID control, the temperature input rises along with the defined temperature curve. As to how to input the temperature setting curve, the machine provides 16 patterns with 16 steps each, together with a linking parameter, a loop parameter, and a number of executions. Each step has 2 parameters (temperature setting value and time). If the initial step has a time parameter set to 0, temperature will rise from room temperature at the initial slope up to the target temperature. After setting these parameters, each temperature controller will have its own set of initial pattern and initial step for creating its own temperature setting curve. Some of the terms are explained as follows:
 - Initial pattern: set the program to start running at a sequential number of patterns
 - Initial Step: set the program to start running at a sequential number of steps
 - Initial Slope: If the time setting of the initial step of the initial pattern is set to 0, an initial slope shall be set to allow the

temperature to rise from room temperature to the setting value.

- d · Step: includes 2 parameter settings: a setting point X and an executing time T, representing the setting value (SV) to rise to X after time T. If the setting point X is identical to the previous setting, this process is called a Soak, otherwise a Ramp, therefore this control procedure is also called a Ramp Soak control. The first running procedure is preset as a Soak control, to set the temperature control to setting point X in advance and maintain the temperature at X, at a duration of T.
- e · Link Parameter: the number of the subsequent pattern to be linked after executing this pattern. If set to END, the program mode will end but maintain the last setting value; if set to STOP, all the program controls will end with the output switched off.
- f · Number of loops: Number of extra loops to be carried out for the pattern. If set to 1, the pattern will be carried out 2 times.
- g · Executing step: Number of steps executed for each pattern.
- h · Wait time, wait temperature: After reaching the program temperature value, a wait time and wait temperature can be set; if the current temperature is not within the range of (temperature setting value \pm wait temperature), the set wait time will start to count down until the currently measured temperature reaches the range of (temperature setting value \pm wait temperature) of each step before proceeding to the subsequent step. An alarm will be issued if the range of (temperature setting value \pm wait temperature) is not reached when the count down reaches 0.

i · Execution:

If the setting control is in running mode, the program will start running from the initial pattern and initial step, and carry out commands one by one.

When the setting control is in end mode, the program will stop running and give out an output disable.

When setting control is in stop control and temperature is controlled at the setting value before the stop, by re-selecting the start status, the program will start running from the initial pattern and initial step.

When setting control is in pause control and temperature is controlled at the setting value before the stop, by re-selecting the start status, the program will start running from the step where the program was paused and carry out the remaining part.

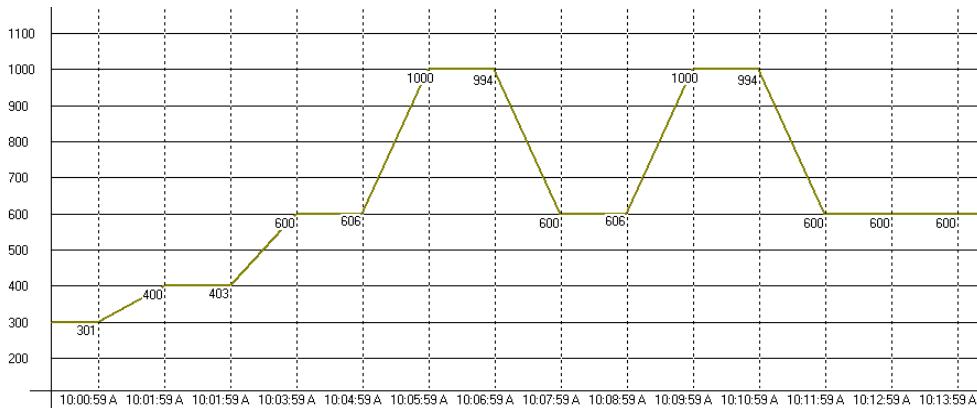

- Set parameter **CLRS** to **PROG** in 【Initial Setting Mode】
- Set initial pattern: Set parameter **PLAN** to initial pattern in 【Operation Mode】 .
- Set initial step: Set parameter **SLEP** to initial step in 【Operation Mode】
- Select edit pattern: Set parameter **PAEN** in 【Initial Setting Mode】 to set the pre-edit pattern, assume selection is 'x'.
Press **◀** key to select the patterns including "SP'x'0", "tM'x'0", "SP'x'1", "tM'x'1"...
"SP'x'F", "tM'x'F", "PSY'x' ", "CYC'x' ", "LiN'x' ", where 'x' is the selected pattern, which can be 0, 1, ..., E, F. "SP'x'0" 、 "SP'x'1" 、 ... "SP'x'F" are temperature settings of this step; "tM'x'0" 、 "tM'x'1" 、 ... "tM'x'F" are time settings of this step; "PSY'x' " is the maximum effective procedure; "CYC'x' " is the number of loops for executing the loop, "LiN'x'" is the number of the subsequent patterns to be linked after executing this pattern.
- Set initial slope: Set initial slope by parameter **SLOP** in 【Initial Setting Mode】 (unit: 0.1°C/min. or 0.1°C/s)
- Set wait temperature: Set wait temperature by parameter **WESV** in 【Initial Setting Mode】 .
- Set wait time: Unit min., set wait time by parameter **W-EM** in 【Initial Setting Mode】 .
- Set unit of program edit time: Set value corresponding to Y position of parameter **EXEL** in 【Initial Setting Mode】 , e.g., xxYx (Y is 0 or 1; 0 : °C/min., 1 : °C/s)
- Set SV display method on program mode: Set value corresponding to Y position of parameter **EXE2** in 【Initial Setting Mode】 , e.g., Yxxx (Y is 0 or 1; 0 : normal, 1 : dynamic)
- Set power off saving on program mode: Set value corresponding to Y position of parameter **EXE2** in 【Initial Setting Mode】 , e.g., xxxY (Y is 0 or 1; 0 : normal., 1 : power off saving)
- **Note: When any settings or changes of the program parameters are made, please save the settings/changes to the**

controller by opting for parameter **SAVE**. Otherwise, the settings/changes will be reset upon power-off.

How to **SAVE**:

- ◇ Select **PRLEN** in the menu, then press the **▼ ▲** keys and select **SAVE** to complete saving. The **SAVE** key is displayed only when any settings/changes are made.
- ◇ Using RS485 communication writing value 1 to address 1129H, the parameters will be saved.

- **Remote Mode:** Input of setting value can be dynamic, an analog value (voltage or current) can be converted into a dynamic input value. Two methods can be used for the conversion: positive slope or negative slope, they are depicted as follows:
 - a · Positive slope Remote setting: Display of Remote analog input is in positive proportion with setting input, e.g.: Remote input type is selected as 1~5 V analog voltage, Remote higher limit of input is set as 5000, Remote lower limit of input is 1000, decimal display is set as 0; when Remote input is 5V, the screen shows 5000; when Remote input is 2V, the screen show 2000; this is the dynamic setting of the screen display. (Dynamic setting value =(Remote higher limit of input – Remote lower limit of input)*(Remote input value - lower limit of Remote input)/(higher limit of Remote input - lower limit of Remote input)+ Remote lower limit of input)
 - b · Negative Slope Remote setting: Display of Remote analog input is in negative proportion with setting input, e.g.: Remote input type is selected as 1~5 V analog voltage, Remote higher limit of input is set as 5000, Remote lower limit of input is 1000, decimal display is set as 0; when Remote input is 5V, the screen shows 1000; when Remote input is 2V, the screen show 4000; this is the dynamic setting of the screen display. (Dynamic setting value =(Remote higher limit of input – Remote lower limit of input)*(Remote input value - lower limit of Remote input)/(higher limit of Remote input - lower limit of Remote input) – Remote lower limit of input)
- Set parameter **LEAS** to **REMO** in **【Initial Setting Mode】**
 - Note: This option is only available when a Remote board is inserted. If the Remote type is of analog current, the JP in the Remote board must be shorted (using a short cap). If the Remote type is of analog voltage, ensure the JP is open.
- Remote type setting: Set type of the Remote input (including analog current 0~20 mA, 4~20mA; analog voltage 0~5V, 1~5V, 0~10V)Set Remote input type by parameter **RMLP** in **【Initial Setting Mode】**
- Remote positive/negative slope setting: Set corresponding value of Y position by parameter **EXEC** in **【Initial Setting Mode】** , e.g.: xYxx (Y can be 0 or 1; 0: positive; 1: negative).
- Remote compensation adjustment: input corresponding lower limit of analog signal at the Remote end, set Remote compensation adjustment by parameter **RM-F** in **【Regulation Mode】**
- Remote gain adjustment: input corresponding upper limit of analog signal at the Remote end, set Remote compensation adjustment by parameter **RM-G** in **【Regulation Mode】**
- Remote lower limit: Setting Remote lower limit by parameter **RM-L** in **【Regulation Mode】**
- Remote higher limit: Setting Remote higher limit by parameter **RM-H** in **【Regulation Mode】**

● **How to setting current input**

Short the Jumper on Remote board.

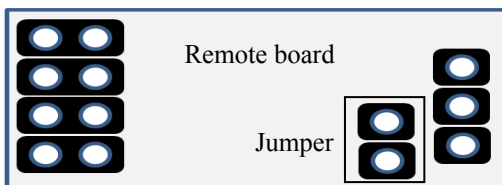

Normal Input (Factory Setting)

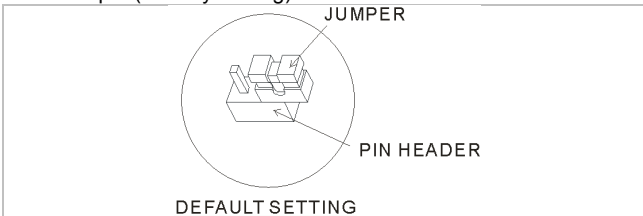

Current Input (4 ~ 20mA, 0 ~ 20mA)

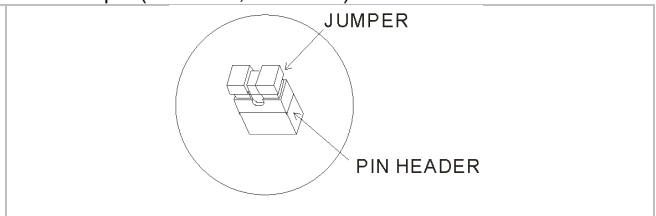

■ Control Mode Setting

There are 4 control modes; ON-OFF, PID, FUZZY and MANUAL.

- **ON-OFF Mode:** For heating output, the output is off when input is greater than the setting value; output is on when input is smaller than (setting value – adjustment sensitivity setting value). For cooling output, the output is on when the input is greater than (setting value + adjustment sensitivity setting value); output is off when input is smaller than the setting value. If one of 2 outputs is set for heating and the other for cooling, a non-action zone can be set as follows.

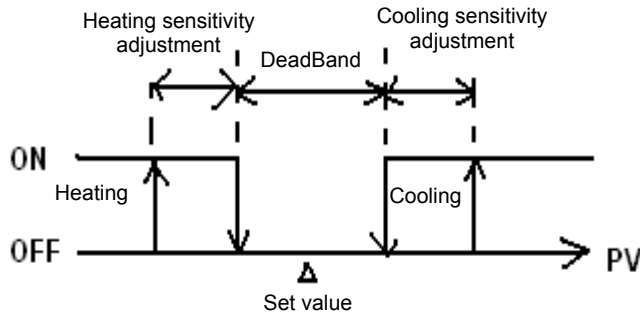

(Output ON-OFF control of both actions)

- Set parameter **CTRL** to **ONOFF** in 【Initial Setting Mode】
- Set adjustment sensitivity: Set adjustment sensitivity by parameter 【Regulation Mode】 to **01-5** (Output 1), **02-5** (output 2)
- Setting of DeadBand of both outputs: Set DeadBand by parameter **DEAD** in 【Regulation Mode】
- **PID Mode:** When set for heating or cooling, the program performs PID operation via input temperature and setting temperature, with the operation result output for the temperature control. A PID parameter and control period must be set for this function; these parameters can also be generated automatically via auto-tuning (AT).
 - A total of six sets of PID parameters are available, one of which can be selected for carrying out PID, and the program may automatically select a set of PID that is most close to the input value. In order to achieve this, each set of PID parameters has a reference input setting value which allows the user to set for manual setting or for auto-tuning (AT). E.G., for the six sets of PID parameters as shown below, SV is reference input setting. Let us select the 4th set as the PID running parameter: i.e., P=40, I=220, D=55, IOF=30%. If we select AT to find the set closest to the setting value with a setting input of 230, the program will automatically find the second set as the running parameter for PID operation.

	0	1	2	3	4	5
SV	80	160	240	320	400	480
P	120	46	70	60	40	50
I	100	140	180	200	220	240
D	25	35	45	50	55	60
IOF	20	10	30	20	30	21

- Set PID parameters and the control period: in which PID parameters can be adjusted manually according to system characteristics or created automatically by AT, the pre-set integral value is set as I parameter $\neq 0$, allowing for promptly achieving the setting value; unit is % output; proportional error compensation is: when I parameter is set to =0, for the adjustment of reduced time to reach the temperature. The Control Period is the period of PID operation, if the control period is 10s, it means a PID operation is carried out every 10s. The result is then output to control the temperature. If the system heats up quickly, the control period shall not be set too long. For relay output, the lifespan of the relay shall be considered; a short period will shorten the lifespan of relay.
- Coef and DeadBand are added in the PID parameter for double output (one for heating and one for cooling). Coef refers to the ratio between the first and second portions of output (P parameter of second group =Coef*P, Coef= 0.01~99.99); DeadBand is the overlapping temperature of the P output of the first group and the second group.
 - Set parameter **CTRL** to **PLD** in 【Initial Setting Mode】
 - To set for heating or cooling control: Select desired output control by parameter **5-HL** in 【Initial Setting Mode】. If no board is inserted in Output2, selection items are: H1, C1 (H for heating, C for cooling, 1 for output 1). If a board is inserted in Output 2, selection items are: H1H2, C1H2... H1A2(H for heating, C for cooling, 1 for output 1, 2 for output 2, A for Alarm 3)
 - Select number of PID sets as running parameter and set PID parameter: Select 0~5, **PLD**, by parameter **PLD** in 【Regulation Mode】, then press **◀** key to set the selected PID parameter including "SV'x", "P'x", "I'x", "d'x", and "ioF'x",

where 'x' is the pre-selected set as the PID running parameter, which can be 0~5. "SV'x" is the reference temperature setting value; "P'x", "I'x", "d'x", "ioF'x" correspond to P, I, D, and IOF.

- Set the control period: in parameter【Regulation Mode】, PV displays "o'x'-y", 'x' is 1(output 1) or 2 (output 2), 'y' is H(Heating) or C (Cooling)
- Set double output Coef: Set Coef value by parameter **COEF** in 【Regulation Mode】
- Set DeadBand of double output: Set DeadBand zone by parameter **DEAD** in 【Regulation Mode】
- Set control to running mode: Set parameter **R-S** in 【Operation Mode】 to **RUN**
- Set AT: Set parameter **AT** to **ON** in 【Regulation Mode】. The selected number of PID will be adjusted automatically. After that, a pre-set parameter of integrated PID value will be created automatically and the display will automatically alter into **OFF**.

Note: When performing AT, the entire system must complete setting; i.e. the input Sensor must be wired and correctly set, and the output must be connected to a heater or cooler pipe.

- **MANUAL Mode:** Manual control function, may force output of a fixed value; normally operated by combining switchover of PID control.

- a、Switch from PID control to manual control: Control output will maintain the original control output before switching over to manual control. E.g., if the control output before the PID calculation is 20%, then the control output after switching to manual control is 20%. You may force a fixed output value after a switchover, for example: controlling the output to be 40%.
- b、Switch from manual control to PID control: if manual control before switching-over to PID control is 40%, the program will take 40% as the initial value for calculating the PID value and output the new control.

Note: If power of machine is switched off in manual control mood, the output % will be maintained when the power is switched on again.

- Set parameter **CTRL** to **MANU** in 【Initial Setting Mode】
- Set control period: in parameter 【Regulation Mode】, PV displays "o'x'-y", 'x' is 1 (output 1) or 2 (output 2), 'y' is H (Heating) or C (Cooling)
- Set output %: in parameter 【Operation Mode】, PV screen displays "oUt'x", 'x' is 1 (output 1) or 2 (output 2)

- **FUZZY Mode:** This comprises 2 parts: PID parameters and Fuzzy exclusive parameters. Since Fuzzy control is calculated based on P.I.D values of PID control, the user must first set P.I.D parameters or perform auto tuning (AT) to produce these parameters. In addition, Fuzzy control includes the following 2 exclusive parameters.

- a、Fuzzy Gain Setting: altering this value will directly affect the calculation of Fuzzy gain. Increasing this value will directly enhance the Fuzzy control; decreasing this value will weaken the Fuzzy control. It is recommended that this value shall be decreased for systems with slow reaction to heating/cooling. This value may be increased for systems with quick reaction to heating/ cooling.
- b、Set Fuzzy DeadBand: The effective bandwidth of Fuzzy control, when PV value enters into the range of SV-FZDB <PV<SV+FZDB, Fuzzy control will stop calculation. I.e., when the PV is within this temperature range, its Fuzzy control is fixed.

- Set parameter **CTRL** to **FUZZ** in 【Initial Setting Mode】
- Set Fuzzy Gain: Set value of Fuzzy Gain by parameter **FZ-R** in 【Regulation Mode】.
- Set Fuzzy DeadBand: Set value of Fuzzy DeadBand by **FZdb** parameter in 【Regulation Mode】.

■ Setting of multiple PID sets

When PID control is selected, the system provides 6 sets (PID 0~5) PID parameter sets (P, I, D and IOF parameter) to be selected by the user. In general conditions, one set of PID (P0) is adequate. For different setting values (SV), when the same PID value is not adequate to control the precision, the user may set up multiple sets of PID parameters for the system to automatically switch-over to an applicable PID set.

- Set only one PID set:

Set parameter **PLD** to 0 (PID 0, the first set) in 【Regulation Mode】, set parameter **AT** to ON; at this time, the System starts to Auto Fine-tune the PID value. During the calculation, AT LED lights up in the display panel. When the PV value generates 2 curves of temperature oscillation based on the SV value, the AT process is completed and the AT LED in the panel goes out. The calculated PID parameters are displayed in **SV0**, **PO**, **CO**, **DO** and **LoFO**, of which their content can be revised by the user.

- Automatic switching-over Multiple PID sets:

Set parameter **PLD** to 0 (PID 0, the first set) in 【Regulation Mode】, set the required SV value (e.g. 100 degree), set parameter **AT** as ON; on completion of auto fine-tuning, the system fills in parameters **SV0** =100, **PO**, **CO**, **DO** and **LoFO** automatically, their content can be revised by the user.

Set parameter **PLD** to 1 (PID 1, the second set), set the required SV value (e.g. 150 degree), set parameter **AT** as ON; on completion of auto fine-tuning, the system fills in parameters **SV1** =150, **P1**, **C1**, **d1** and **LoF1** automatically.

Set parameter **PLD** to AUTO, System will verify on its own whether the current SV value is closer to parameter **SV0** or **SV1**, and load the corresponding PID set automatically. E.g., if SV=110, system will load **SV0** parameters. If SV=140, system will load **SV1** parameters.

If more SV groups are required, PID2~PID5 can be set up with the same sequence as described above.

■ Tune Function

This machine provides 2 tuning methods (Auto_Tuning and Self_Tuning) for automatic generation of PID parameters (only applicable when control mode is set to PID control).

- Auto_Tuning: by full output of heating or cooling, temperature is allowed to oscillate up and down. Attain parameters of the magnitude and period, calculate P, I, D, IOF parameters; in addition, save the temperature setting value for performing AT, for the use of PID control. After Auto_Tuning, PID control will be carried out automatically.
 - Set parameter **EUNE** to **AE** in 【Initial Setting Mode】
 - AT setting: Set parameter **AE** to **ON** in 【Regulation Mode】
- Self_Tuning: By full output of heating or cooling, max. slope of temperature alteration and system delay can be attained from the Temperature-Time Curve, and P, I, D, IOF parameters can be calculated. Self tuning can be carried out in RUN mode and in STOP mode. In the RUN mode, PID parameters are allowed to be updated when the machine is running; in the STOP mode, PID parameters for the SV value can be attained.
 - Set parameter **EUNE** to **SE** in 【Initial Setting Mode】
 - ST Setting: set parameter **SE** to **ON** in 【Regulation Mode】

■ Set Reverse Output

- output 1 reverse setting: Set a value corresponding to Y position by parameter **oELN** in 【Initial Setting Mode】 , such as xxxY (Y can be 0 or 1; 0: forward; 1: reverse)
- output 2 reverse setting: Set a value corresponding to Y position by parameter **oELN** in 【Initial Setting Mode】 , such as xxYx (Y can be 0 or 1; 0: forward; 1: reverse)

■ Limits controlling the output range

Maximum and minimum output can be limited; if the original maximum control output is 100% and the minimum control output is 0%, you may set the maximum control output to 80% and the minimum control output to 20%.

- Setting the upper limit of control output: Set values for parameters **o1MA** (output 1), **o2MA** (output 2) in 【Operation Mode】 .
- Setting the lower limit of control output: Set values for parameters **o1ML** (output 1), **o2ML** (output 2) in 【Operation Mode】 .

■ CT Function

This controller provides maximum 2 CTs (CT1 and CT2) for measuring current values of output 1 and output 2; when the corresponding output is ON, use CT to measure the corresponding current. An alarm will be activated (ON) when the current exceeds the setting range of alarm. (A hardware PCB is required.)

- Insert CT1, CT2 PCBs to Option1, Option2
- Set the corresponding alarm to CT Alarm: Please refer to “Alarm Output Setting”.
- Set the upper limit of CT alarm output (unit: 0.1A): Please refer to “Alarm Output Setting”.
- Set the lower limit of CT alarm output (unit: 0.1A): Please refer to “Alarm Output Setting”.
- Read current values of CT1, CT2: Read current values by parameters **CT1**, **CT2** in 【Operation Mode】 .
- Select CT measurement range
 - CT1 100A setting : Set a value corresponding to Y position by parameter **E*E2** in 【Initial Setting Mode】 , such as xxYx (Y can be 0 or 1; 0: 30A; 1: 100A)
 - CT2 100A setting : Set a value corresponding to Y position by parameter **E*E2** in 【Initial Setting Mode】 , such as xYxx (Y can be 0 or 1; 0: 30A; 1: 100A)

Short the jumper on CT board.

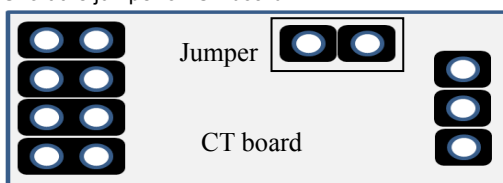

Normal input (default setting 30A)

Short (100A)

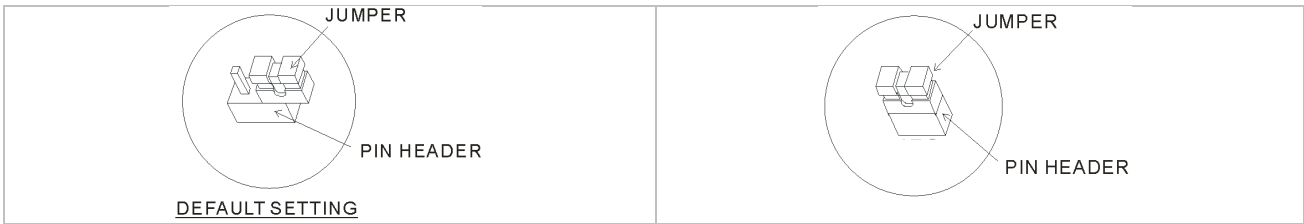

■ EVENT Function

This controller provides a maximum of 3 EVENTS (EV1~EV3) for respectively setting EV functions as shown in the following Table <1>. For example, if EV1 is used for Run/Stop selection, when the controller is set to RUN status, if terminals in the Option1 slot are open, the controller is in RUN status; if terminals in the Option1 slot are shorted, the controller switches to STOP status.

Function setting	OFF	R-S	SV2	MANU	P-Hd
Function	Disable	Run/Stop	SV 1/ SV 2	Auto/ Manual	Run/ Hold

Table <1> EVT function setting

Run/Stop: This function switches the controller between RUN and STOP status.

SV 1/SV 2: This function selects SV 1 or SV 2 as the active setpoint.

Auto/Manual: This function selects PID and Manual control.

Run/Hold: This function switches controller between run and hold status when in program control.

- Insert EV1, EV2 PCB to Option1 or Option2, or insert hardware with a built-in EV3 function
- Set EV functions as listed in **Table <1> EVT Function Setting** by parameters **EV1**, **EV2**, **EV3** in **【Regulation Mode】**.

Note: Selection of “Evt’x” items must match with the inserted PCB; if only Option1 is inserted, then only “Evt1” will be displayed.

■ Limits of temperature ranges

Different input sensors have different application ranges (e.g.: J type factory setting is -100 ~ 1200°C), adjust parameters **EP-H** (upper limit) / **EP-L** (lower limit) in Initial Setting Mode.

If lower limit is altered to 0 and upper limit is altered to 200, the limit function will be enabled in the following conditions:

- When setting the SV value, the limits may set for 0~200°C
- In ON-OFF, PID, FUZZY and Self-Tuning control conditions, the control output will be forced to shut off if the PV value exceeds the upper/lower limit. (Alarm output is still normal)

■ User Setting of F1, F2 function keys

In the Operation Mode, (PV/SV display mode), pressing a function key more than 3 seconds will prompt you to the setting of the following functions; press **▼** **▲** keys to make a selection.

Function	Description
MENU	When in a screen other than the PV/SV display mode, pressing F1/F2 key continuously may save the setting, to quickly switch the menu screen (When the screen shows KEY SAVE, the menu screen is saved)
AT	Selecting this function, F1 / F2 button can be used for quick ON / OFF operation of AT function
R-S	Selecting this function, F1 / F2 button can be used to switch between RUN/STOP status.
PROG	Selecting this function, F1 / F2 button can be used to switch between RUN/HOLD status.
ATMT	Selecting this function, F1 / F2 button can be used to switch between PID and MANUAL control mode
ALRS	Selecting this function, F1 / F2 button can be used to reset Alarm Hold status.
SV2	Selecting this function, F1 / F2 button can be used to switch between SV1/SV2.

For disabling F1/F2 function, please select **【MENU】** without saving any menu screen.

■ Edit a self-defined Menu Screen

Hidden MENU setting: Lock all buttons by adjusting parameter **LoL** to **LoL1** in **【Operation Mode】**. At the same time press **SET** and **▲** keys for 3 seconds to display **PASS**, and enter Password-1. The screen will show menu number **M101**, see the following table for details. Select “Hide” to hide the Menu.

Menu Layer setting: Lock all buttons by adjusting parameter **LoL** to **LoL1** in **【Operation Mode】**. At the same time press **SET** and **▲** keys for 3 seconds to display **PASS**, and enter Password-2. The screen will show menu number **M101**, see the following

table for details. Selectable items are NOR= display layers; ADJ= adjust layers; SET= set layers.

Menu layer reset: Lock all buttons by adjusting parameter **LoC** to **LoC1** in **【Operation Mode】**. At the same time press **SET** and **▲** keys for 3 seconds to display **PASS**, and enter Password-3. The screen displays **LVRE** (Level reset) parameters, select **YES** to reset all menu layers to default setting.

RUN layer		Adjust layer		Setting layer	
Menu No.	Corresponding menu	Menu No.	Corresponding menu	Menu No.	Corresponding menu
M101	1234	M201	AL	M301	LNPL
M102	R-S	M202	SE	M302	EPUN
M103	PLRN	M203	PLd	M303	EP-H
M104	SEEP	M204	SWD	M304	EP-L
M105	SP	M205	PD	M305	CLRL
M106	LoC	M206	CO	M306	CLRS
M107	AL 1H	M207	dB	M307	WESW
M108	AL 1L	M208	LoFD	M308	W-EM
M109	AL 2H	M209	Pdof	M309	SLoP
M110	AL 2L	M210	FZ-R	M310	PAEN
M111	AL 3H	M211	FZdb	M311	EUNE
M112	AL 3L	M212	o1-S o1-L	M312	S-HL
M113	A 1HP	M213	o2-S o2-L	M313	AL A1
M114	A 1LP	M214	o1-H	M314	AL 1o
M115	A 2HP	M215	o2-L	M315	AL 1d
M116	A 2LP	M216	LoEF	M316	AL A2
M117	A 3HP	M217	dEAd	M317	AL 2o
M118	A 3LP	M218	PV-F	M318	AL 2d
M119	oUt 1	M219	PV-R	M319	AL A3
M120	oUt 2	M220	PVof	M320	AL 3o
M121	o 1MA	M221	PVbA	M321	AL 3d
M122	o 1ML	M222	SVSL	M322	PVCL
M123	o 2MA	M223	A 1MA	M323	oELN
M124	o 2ML	M224	A 1ML	M324	PdSW
M125	CL 1	M225	A 2MA	M325	PdRL
M126	CL 2	M226	A 2ML	M326	RMELP
		M227	ALMA	M327	EXEC
		M228	ALML	M328	EXE2
		M229	RM-G	M329	LoSH
		M230	RM-F	M330	C-SL
		M231	RM-L	M331	C-No
		M232	RM-H	M332	bPS
		M233	EVL 1	M333	LEN
		M234	EVL 2	M334	StoP
		M235	EVL 3	M335	PRLY

■ Restore Factory Settings

Lock all buttons by adjusting parameter **LoL** to **LoL1** in **【Operation Mode】**. At the same time press **SET** and **▲** keys for 3 seconds to display **PASS**, and enter Password-1357. The screen displays **PRRE** (Parameter reset), selecting **YES** will overwrite all user settings with factory settings.

■ Key Lock Function

Adjusting parameter **LoL** to **LoL1** in **【Operation Mode】** will lock all keys; adjusting the parameter to **LoL2** allows adjustment of SV setting values and F1/F2 function keys.

➤ Unlock the key:

Press **SET** and **▼** keys at the same time in LOCK mode to display **KEYP** parameter, enter the password to unlock the key. Default password is 0000.

➤ For altering key-lock password:

1. Press **◀** key in **KEYP** screen to enter change-password screen **CHGP**
2. Enter the current password in **CHGP** screen. If the password is correct, you will be prompted to Set-New-Password screen **NEWP**. If the password is incorrect, the screen will return to PV/SV display mode.
3. Enter the new password two times in the **NEWP** screen. The screen will return to PV/SV display mode with the keys unlocked. If the two entries of password are not the same, the screen will go back to the state of step 2.

➤ Cannot remember the password:

Restore factory settings to release the locking.

■ Alarm Outputs

Two alarm outputs are provided in the machine, a maximum of 3 alarm outputs can be expanded. A total of 19 Independent alarm settings can be made as listed in the table. Additional settings are provided, such as alarm delay, alarm standby, alarm output hold, alarm reverse output, and alarm peak record, as described as follows:

- a · Alarm Delay Setting: Sets alarm delay time. When the movement conforms to the alarm setting mode, controller will delay the generation of an alarm signal; an alarm will only be activated when the alarm conditions remains confirmed within the delayed period of time.
- b · Alarm Standby Setting: An alarm detection will only be activated when the measured value falls within the ± 5 range of the specified input value, so as to prevent an alarm activation on the start-up if the condition conforms to the alarm setting.
- c · Alarm Output Hold Setting: The alarm message will be held when the alarm activates, unless the control switches off the alarm.
- d · Alarm Reverse Output Setting: An alarm output can be set for NC(Normal close) or NO(Normal Open).
- e · Alarm Peak Record Setting: For recording the peak value of the alarm signal.

Set Value	Alarm Type	Alarm Output Operation
0	Alarm function disabled	
1	Deviation upper- and lower-limit: This alarm output operates when PV value is higher than the setting value SV+(AL-H) or lower than the setting value SV-(AL-L).	<p>ON OFF SV-(AL-L) SV SV+(AL-H)</p>
2	Deviation upper-limit: This alarm output operates when PV value is higher than the setting value SV+(AL-H).	<p>ON OFF SV SV+(AL-H)</p>
3	Deviation lower-limit: This alarm output operates when PV value is lower than the setting value SV-(AL-L).	<p>ON OFF SV-(AL-L) SV</p>
4	Absolute value upper- and lower-limit: This alarm output operates when PV value is higher than the setting value AL-H or lower than the setting value AL-L.	<p>ON OFF AL-L AL-H</p>
5	Absolute value upper-limit: This alarm output operates when PV value is higher than the setting value AL-H.	<p>ON OFF AL-H</p>
6	Absolute value lower-limit: This alarm output operates when PV value is lower than the setting value AL-L.	<p>ON OFF AL-L</p>

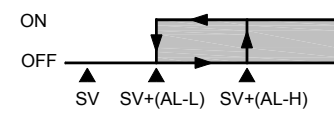
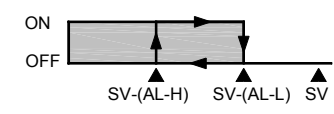
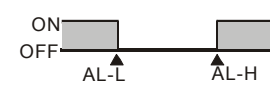
7	Hysteresis upper-limit alarm output: This alarm output operates if PV value is higher than the setting value SV+(AL-H). This alarm output is OFF when PV value is lower than the setting value SV+(AL-L).	
8	Hysteresis lower-limit alarm output: This alarm output operates if PV value is lower than the setting value SV-(AL-H). This alarm output is OFF when PV value is higher than the setting value SV-(AL-L).	
9	Disconnection Alarm: This alarm output operates if the sensor connection is incorrect or has been disconnected.	
10	None	
11	CT1 Alarm: CT1 is ON if the value of CT1 is lower than the value of AL-L or higher than AL-H.	
12	CT2 Alarm: CT2 is ON if the value of CT2 is lower than the value of AL-L or higher than AL-H.	
13	When SOAK status (temperature hold) happens to PID program control, alarm output is ON.	
14	When RAMP UP status happens to PID program control, alarm output is ON.	
15	When RAMP DOWN status happens to PID program control, alarm output is ON.	
16	When RUN status happens to PID program control, alarm output is ON.	
17	When HOLD status happens to PID program control, alarm output is ON.	
18	When STOP status happens to PID program control, alarm output is ON.	
19	When END status happens to PID program control, alarm output is ON.	

- To set Alarm Mode: Use the parameters **ALA1**, **ALA2**, **ALA3** in **【Initial Setting Mode】** to select the alarm mode. There are in total of 19 different modes (as listed in the table above).
- To set Deviation Upper Limit of Alarm: Use the parameters **AL1H**, **AL2H**, **AL3H** in **【Operation Mode】** to set the deviation upper limit.
- To set Deviation Lower Limit of Alarm: Use the parameters **AL1L**, **AL2L**, **AL3L** in **【Operation Mode】** to set the deviation lower limit.
- To set Alarm Delay Time(Unit: seconds): Use the parameters **AL1d**, **AL2d**, **AL3d** in **【Initial Setting Mode】** to set the alarm delay time.
- To set Reverse Alarm: Use the parameters **AL1a**, **AL2a**, **AL3a** in **【Initial Setting Mode】** to set the digit Y of value xxYx (When Y=0: reverse, Y=1: forward)
- To set Alarm 3: Alarm 3 function is available when an output board is connected to Output 2. Use the parameter **S-HC** in **【Initial Setting Mode】**, press the key **▲** or **▼** to select for the following control output items: H1H2, C1H2... H1A2(H defines heating, C defines cooling, 1 indicates Output1, 2 indicates Output2, A indicates Alarm3).
- Select x1A2(set x to H or C) to operates Alarm3. To set Standby Alarm: Use the parameters **AL1a**, **AL2a**, **AL3a** in **【Initial Setting Mode】** to set the digit Y of value xxxY (When Y=0: normal operation, Y=1: standby).
- To set Hold Alarm: Use the parameters **AL1a**, **AL2a**, **AL3a** in **【Initial Setting Mode】** to set the digit Y of value xYxx (When Y=0: normal operation, Y=1: Hold).
- To set Peak Alarm Signal: Use the parameters **AL1a**, **AL2a**, **AL3a** in **【Initial Setting Mode】** to set the digit Y of value Yxxx (when Y=0: normal operation, Y=1: peak signal).

Note: Refer to the table

Bit3	Bit2	Bit1	Bit0
Peak Alarm	Hold Alarm	Reverse Alarm	Standby Alarm

- PV Color Change Function: This controller provides PV color change function. The PV display color will be changed if the selected alarm energized. Use the parameter **PVL** (PV color) in **【Initial Setting Mode】** to select the alarm, selectable items are **OFF**, **ALL**, **ALA1**, **ALA2** and **ALA3**.

■ RS-485 Communication

1. Supporting transmission speed: 2,400, 4,800, 9,600, 19,200, 38,400bps
2. Non-supported formats: 7, N, 1 or 8, O, 2 or 8, E, 2
3. Communication protocol: Modbus (ASCII or RTU)
4. Function code: 03H to read the contents of register (Max. 8 words). 06H to write 1 (one) word into register. 02H to read the bits data (Max.16 bits). 05H to write 1 (one) bit into register.
5. Address and Content of Data Register:

Address	Content	Definition
1000H	Present value (PV)	Measuring unit is 0.1, updated one time in 0.1 second The following reading value display indicates error occurs: 8002H : Initial process (Temperature value is not got yet) 8003H : Temperature sensor is not connected 8004H : Temperature sensor input error 8006H : Cannot get temperature value, ADC input error 8007H : Memory read/write error
1001H	Set point (SV)	Unit is 0.1, oC or oF
1002H	Upper-limit of temperature range	The data content should not be higher than the temperature range
1003H	Lower-limit of temperature range	The data content should not be lower than the temperature range
1004H	Input temperature sensor type	Please refer to the contents of the "Temperature Sensor Type and Temperature Range" for detail
1005H	Control method	0: PID, 1: ON/OFF, 2: manual tuning, 3: FUZZY
1006H	Heating/Cooling control selection	Refer to Ouput Mode Selection
1007H	1st group of Heating/Cooling control cycle	1~990, unit is 0.1 second. When the output setting = realy, the minimum control cycle is 5 second
1008H	2nd group of Heating/Cooling control cycle	1~990, unit is 0.1 second. When the output setting = realy, the minimum control cycle is 5 second 1~990
1009H	PB Proportional band	0.1 ~ 999.9
100AH	Ti Integral time	0~9,999
100BH	Td Derivative time	0~9,999
100CH	Integration default	0 ~ 100%, unit is 0.1%
100DH	Proportional control offset error value, when Ti=0	0 ~ 100%, unit is 0.1%
100EH	The setting of COEF when Dual Loop output control are used	0.01 ~99.99, unit is 0.01
100FH	The setting of Dead Band when Dual Loop output control are used	-99.9 ~ 999.9
1010H	Hysteresis setting value of the 1st output group	-99.9~999.9
1011H	Hysteresis setting value of the 2nd output group	-99.9~999.9
1012H	Output value read and write of Output 1	Unit is 0.1%, write operation is valid under manual tuning mode only.
1013H	Output value read and write of Output 2	Unit is 0.1%, write operation is valid under manual tuning mode only.
1016H	Temperature regulation value	-99.9 ~ +99.9. Unit is 0.1
1017H	Analog decimal setting	0 ~ 3
101CH	PID parameter selection	0~5/AUTO
101DH	SV value corresponded to PID value	Only valid within available range, unit: 0.1 scale
1020H	Alarm 1 type	Please refer to the contents of the "Alarm Outputs" for detail
1021H	Alarm 2 type	Please refer to the contents of the "Alarm Outputs" for detail
1022H	Alarm 3 type	Please refer to the contents of the "Alarm Outputs" for detail
1024H	Upper-limit alarm 1	Please refer to the contents of the "Alarm Outputs" for detail
1025H	Lower-limit alarm 1	Please refer to the contents of the "Alarm Outputs" for detail

1026H	Upper-limit alarm 2	Please refer to the contents of the "Alarm Outputs" for detail
1027H	Lower-limit alarm 2	Please refer to the contents of the "Alarm Outputs" for detail
1028H	Upper-limit alarm 3	Please refer to the contents of the "Alarm Outputs" for detail
1029H	Lower-limit alarm 3	Please refer to the contents of the "Alarm Outputs" for detail
102AH	Read LED Status	b0: ALM3, b1: ALM2, b2: °C, b3: °F, b4: ALM1, b5: OUT2, b6:OUT1, b7: AT
102BH	Read Pushbutton Status	b1: F2, b2: Up, b3: Loop, b5: F1, b6: Down, b7: Set, 0: press down key
102CH	Setting lock status	
102FH	Software version	V1.00 indicates 0x100
1030H	Start pattern number	0 ~ 15
1039H	Communication write	0: Disable (default), 1: Enable
103AH	Temperature unit display selection	0: °F, 1: °C / linear input (default)
103BH	AT setting	0: OFF (default), 1: ON
103CH	Control RUN/STOP setting	0: STOP, 1: RUN (default), 2:END (program mode), 3: HOLD (program mode)
101FH	Start step number	0 ~ 15
1200H~13FFH	Pattern 0~15 temperature set point setting (Even number) Pattern 0~15 execution time setting (Odd number)	-999 ~ 9999 Time: 0 ~ 900 (1 minute per scale)
1400H~140FH	Actual number of step setting inside the corresponding pattern	0 ~ 15 = N, indicate that this pattern is executed from step 0 to step N
1410H~141FH	Cycle number for repeating the execution of the correspond pattern	0 ~ 99 indicate that this pattern has been executed for 1 ~ 100 times
1420H~142FH	Link pattern number setting of the correspond pattern	0 ~ 15, 16 indicates the program end and keep in present step. 17 indicates the program end and execution end. 0~15 indicates the next execution pattern number after executing the current pattern

Address	Content	Definition
1100H	Adjust Temperature Gain	
1101H	Temperature Filter Range	Range of temperature filter: 10~1000, unit: 0.01 °C, default: 100(1.0°C)
1102H	Temperature Filter Factor	Setting range: 0~50, default: 8
1103H	Reverse Output	Bit1: output 2, Bit0: output 1
1104H	Slope of Temperature Increase	Unit: 0.1°C/min or 0.1°C/sec (refer to CommunicationAddress 1124H)
1105H	Remote Input Type Selection	0: 0~20m A, 1: 4~20m A, 2: 0~5V, 3: 1~5V, 4: 0~10V
1106H	AT Control	0: AT(Auto-tune), 1: ST(Self-tune)
1107H	Remote Input Reverse Setting	0: forward, 1: reverse
1108H	Alarm 1 Function Selection	Bit3: Peak Record, Bit2: Hold Enable, Bit1: Output Reverse, Bit0: Standby Enable
1109H	Alarm 2 Function Selection	Bit3: Peak Record, Bit2: Hold Enable, Bit1: Output Reverse, Bit0: Standby Enable
110AH	Alarm 3 Function Selection	Bit3: Peak Record, Bit2: Hold Enable, Bit1: Output Reverse, Bit0: Standby Enable
110BH	Alarm 1 Output Delay Time	Unit: second. Setting range: 0~100sec
110CH	Alarm 2 Output Delay Time	Unit: second. Setting range: 0~100sec
110DH	Alarm 3 Output Delay Time	Unit: second. Setting range: 0~100sec
110EH	Upper Limit of Control Output 1	Range: lower limit of control output ~100%, unit is 0.1%
110FH	Lower Limit of Control Output 1	Range: 0~upper limit of control output, unit is 0.1%
1110H	Upper Limit of Control Output 2	Range: lower limit of control output~100%, unit is 0.1%
1111H	Lower Limit of Control Output 2	Range: 0~upper limit of control output, unit is 0.1%
1112H	Programmable Waiting Temperature	Setting range: 0~1000(100.0°C)
1113H	Programmable Waiting Time	Unit: min. Setting range: 0~900
1114H	Programmable Slope Increase	Unit: 0.1°C/min or 0.1°C/sec--- (refer to Communication Address 1124H) Setting range: 0~1000
1115H	Testing Mode	
1116H	Adjust Upper Limit of Analog Linear Output 1	Adjust current: 1scale=1µA, Adjust voltage: 1scale=1mV
1117H	Adjust Lower Limit of Analog Linear Output 1	Adjust current: 1scale=1µA, Adjust voltage: 1scale=1mV

1118H	Adjust Upper Limit of Analog Linear Output 2	Adjust current: 1scale=1μA, Adjust voltage: 1scale=1mV
1119H	Adjust Lower Limit of Analog Linear Output 2	Adjust current: 1scale=1μA, Adjust voltage: 1scale=1mV
111AH	Adjust Retransmission Upper Limit	Adjust current: 1scale=1μA
111BH	Adjust Retransmission Lower Limit	Adjust current: 1scale=1μA
111CH	Event 1 Selection	0: OFF, 1: Run/Stop, 2: Change SV value, 3: PID/Manual control, 4: Switch to Programmable Hold mode
111DH	Event 2 Selection	0: OFF, 1: Run/Stop, 2: Change SV value, 3: PID/Manual control, 4: Switch to Programmable Hold mode
111EH	Event 3 Selection	0: OFF, 1: Run/Stop, 2: Change SV value, 3: PID/Manual control, 4: Switch to Programmable Hold mode
1120H	SV Control Mode Selection	0: Constant, 1: Slope increase, 2: Programmable input, 3: Remote Input
1121H	Adjust Remote Compensation	Setting range: -999~999
1122H	Adjust Remote Gain	Setting range: -999~999
1123H	Positive/Negative Selection for Remote	0: Positive, 1: Negative
1124H	Switch Slope Time Unit	0: min, 1: sec
1125H	Cold Junction Compensation	0: ON, 1: OFF
1126H	Reserve the Programmable Running Status when Power OFF	0: None, 1: Running status is saved and will continue by the previous status when power ON.
1127H	Fuzzy Gain	Setting range: 1~10
1128H	Fuzzy Dead Band	Setting range: 0.0~PB
1129H	Save Programmable Settings into Memory	0:None, 1: Saves the programmable settings into memory
1182H	CT1 Read Value	Unit: 0.1A
1183H	CT2 Read Value	Unit: 0.1A

1. Communication Transmission Format: Command Code: 03: read words, 06: write 1 word

ASCII Mode

Read Command			Read Command Response			Write Command			Write Command Response		
STX	':'	':'	STX	':'	':'	STX	':'	':'	STX	':'	':'
ADR 1	'0'	'0'	ADR 1	'0'	'0'	ADR 1	'0'	'0'	ADR 1	'0'	'0'
ADR 0	'1'	'1'	ADR 0	'1'	'1'	ADR 0	'1'	'1'	ADR 0	'1'	'1'
CMD 1	'0'	'0'	CMD 1	'0'	'0'	CMD 1	'0'	'0'	CMD 1	'0'	'0'
CMD 0	'3'	'2'	CMD 0	'3'	'2'	CMD 0	'6'	'5'	CMD 0	'6'	'5'
Starting data address	'1'	'0'	Number of data (count by byte)	'0'	'0'	Starting data address	'1'	'0'	Starting data address	'1'	'0'
	'0'	'8'		'4'	'2'		'0'	'8'		'0'	'8'
	'0'	'1'		Start address data	'0'		'1'	'0'		'1'	'0'
'0'	'0'	'1'	'7'		'1'	'0'	'1'	'0'			
Number of data (word/Bit)	'0'	'0'	1000H/081xH	'F'	'0'	Data content	'0'	'F'	Data content	'0'	'F'
	'0'	'0'		'4'	'1'		'3'	'F'		'3'	'F'
	'0'	'0'		'0'			'E'	'0'		'E'	'0'
LRC 1	'2'	'9'	Address data	'0'		LRC1	'8'	'0'	LRC1	'8'	'0'
	'E'	'D'		1001H	'0'			'F'		'E'	'F'
LRC 0	'A'	'C'		'0'		LRC 0	'D'	'3'	LRC 0	'D'	'3'
END 1	CR	CR	LRC 1	'0'	'E'	END 1	CR	CR	END 1	CR	CR
END 0	LF	LF	LRC 0	'3'	'3'	END 0	LF	LF	END 0	LF	LF
			END 1	CR	CR						
			END 0	LF	LF						

LRC checksum:

LRC check is the added sum from "Address" to "Data content". For example, 01H + 03H + 10+ 00H + 00H + 02H = 16H, then take the complementary of 2, EAH.

RTU Mode

Read Command			Read Command Response			Write Command			Write Command Response		
ADR	01H	01H	ADR	01H	01H	ADR	01H	01H	ADR	01H	01H
CMD	03H	02H	CMD	03H	02H	CMD	06H	05H	CMD	06H	05H
Starting data address	10H	08H	Number of data (count by byte)	04H	02H	Starting data address	10H	08H	Starting data address	10H	08H
	00H	10H					01H	10H		01H	10H
Number of data (word/Bit)	00H	00H	Start address data 1000H/081xH	01H	17H	Data content	03H	FFH	Data content	03H	FFH
	02H	09H		F4H	01H		20H	00H		20H	00H
CRC 1	C0H	BBH	Address data1001H	03H		CRC 1	DDH	8FH	CRC 1	DDH	8FH
CRC 0	CBH	A9H		20H		CRC 0	E2H	9FH	CRC 0	E2H	9FH
			CRC 1	BBH	77H						
			CRC 0	15H	88H						

CRC (Cyclical Redundancy Check) is obtained by the following steps.

1. Load in a 16-bit register FFFFH as the CRC register.
2. Do an exclusive OR operation of the first byte of the data and low byte of CRC register, and place the operation result back to the CRC register.
3. Right shift the bits in the CRC register and fill the high bits with "0". Check the removed lowest bit.
4. If the removed lowest bit is "0", repeat step 3. Otherwise, do an exclusive OR operation of the CRC register and the value A001H and place the operation result back to the CRC register.
5. Repeat step 3 and 4 until the 8 bits (1 byte) are all right shifted.
6. Repeat step 2 and 5 and calculate all the bits to obtain CRC check.

Please be aware of the high/low byte transmission order in the CRC register.

■ Panel Cutout

Pattern	Panel Cutout (W * H)	Model	Panel Cutout (W * H)
4848 (DT320)	45mm * 45mm	7272 (DT330)	68mm * 68mm
4896 (DT340)	44.5mm * 91.5mm	9696 (DT360)	91mm * 91mm

■ Wiring diagram

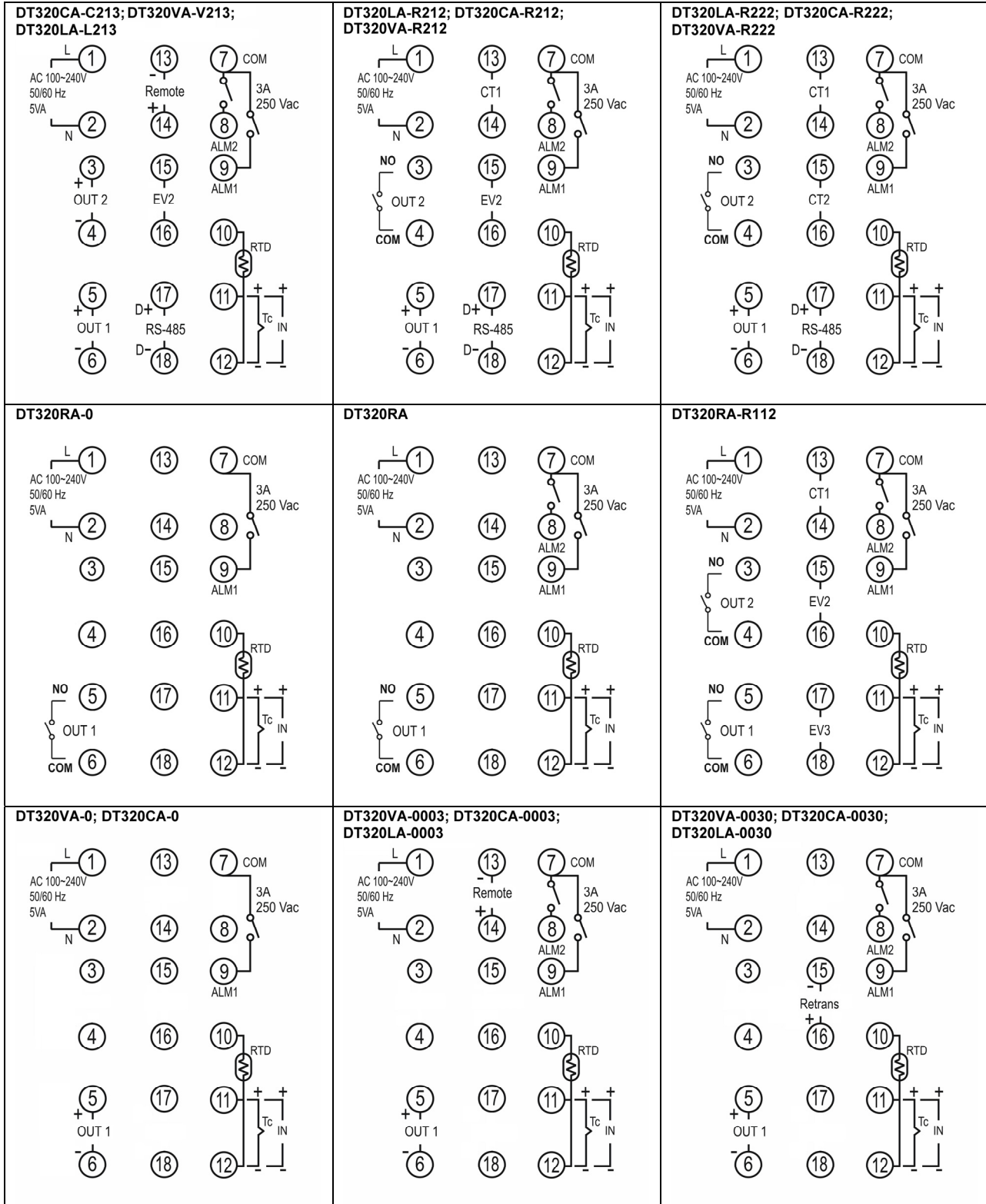

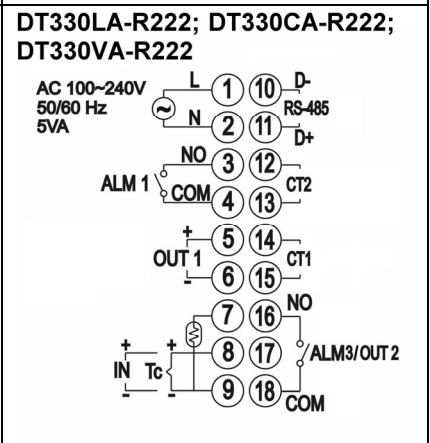
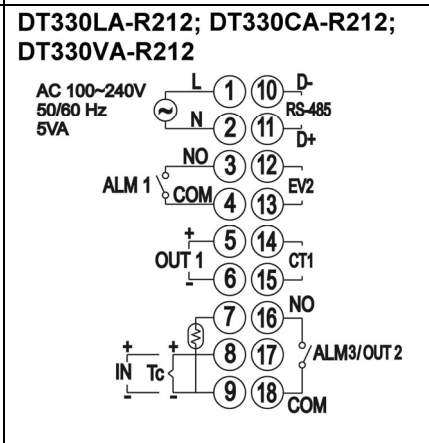
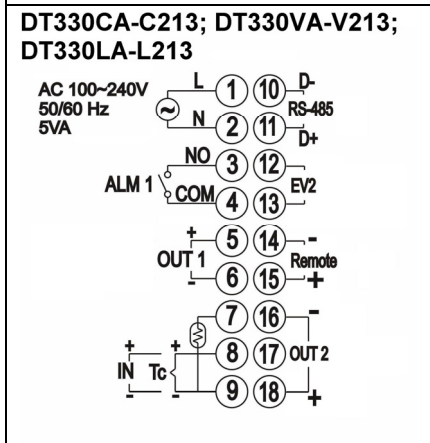
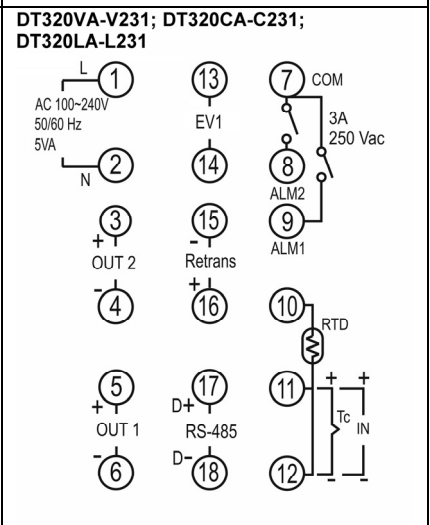
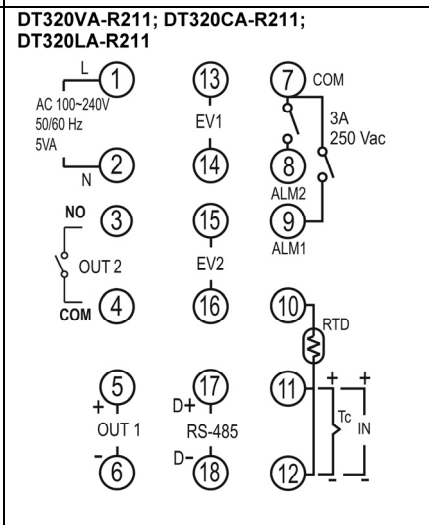
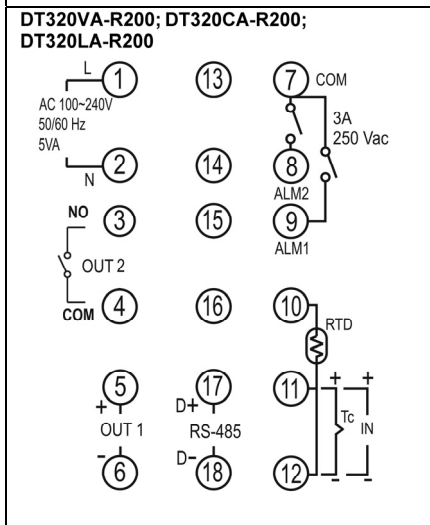
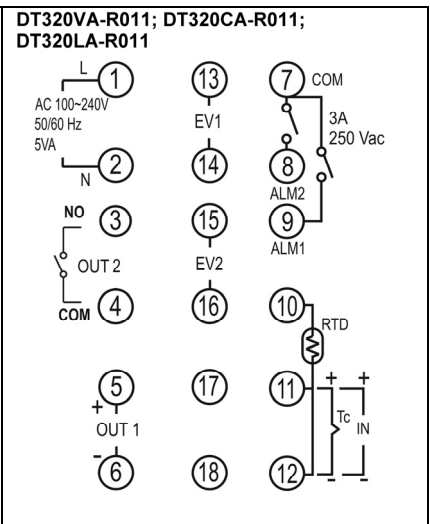
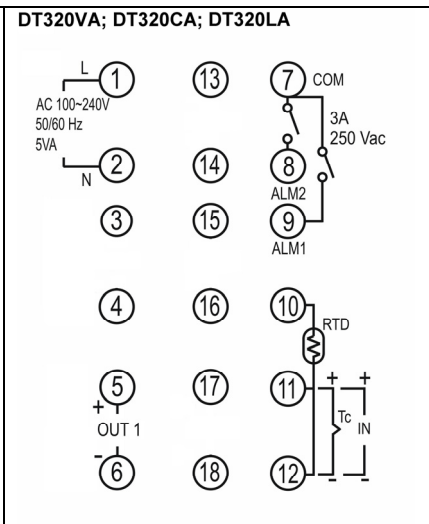
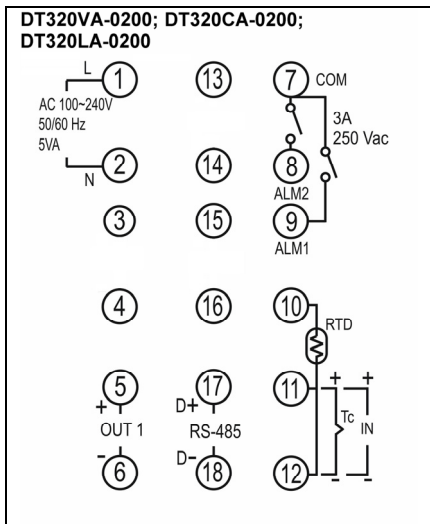

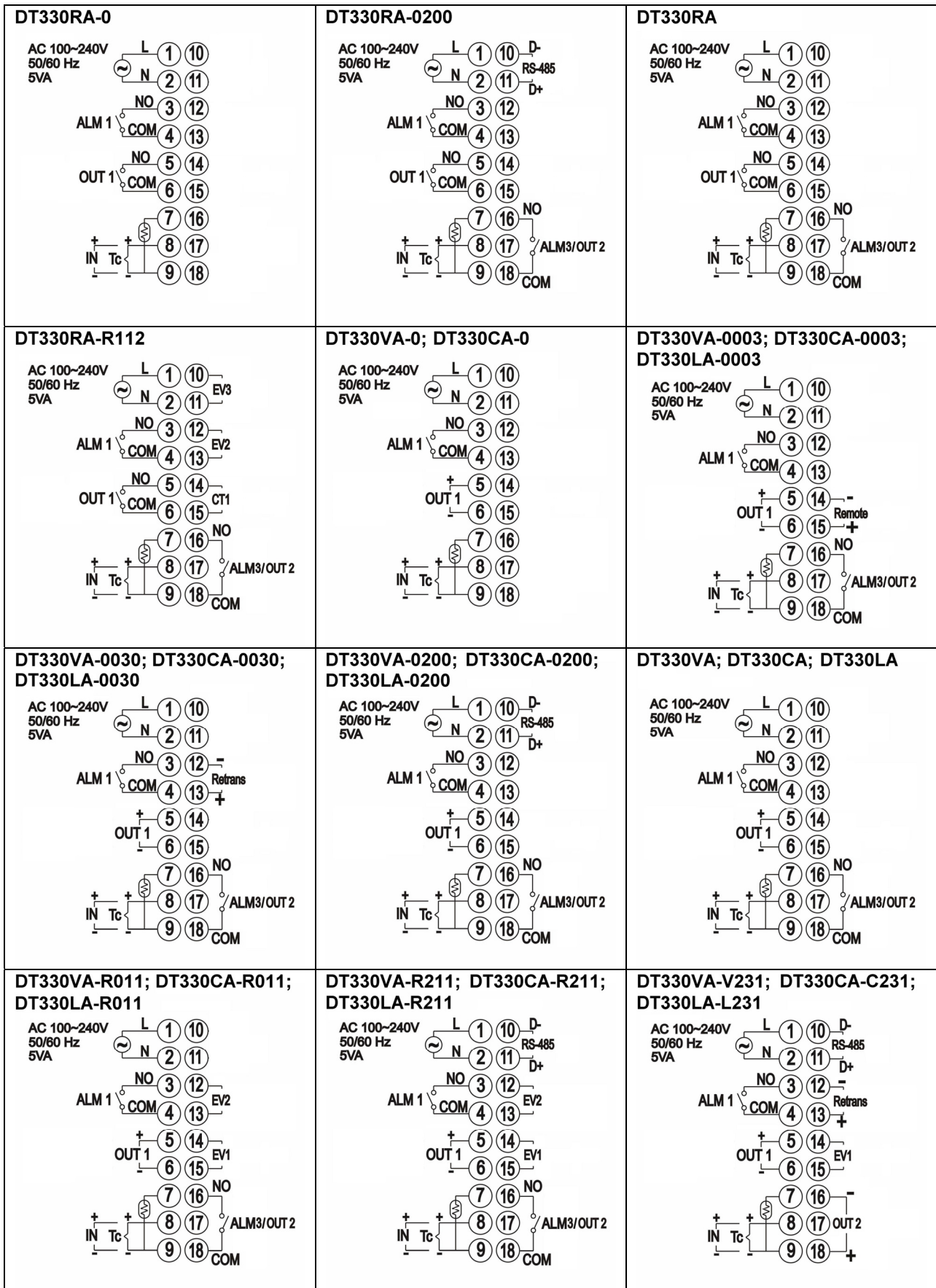

**DT340CA-C213; DT360CA-C213;
DT340VA-V213; DT360VA-V213**

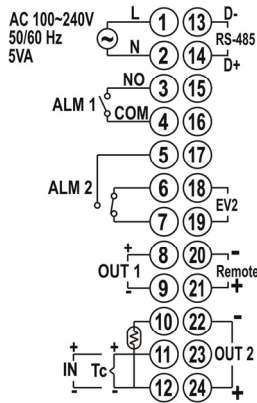

**DT340LA-R212; DT360VA-R212;
DT340CA-R212; DT360CA-R212;
DT340VA-R212**

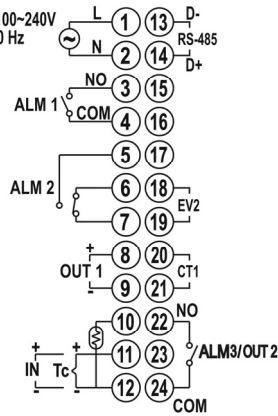

**DT340LA-R222; DT360VA-R222;
DT340CA-R222; DT360CA-R222;
DT340VA-R222.....**

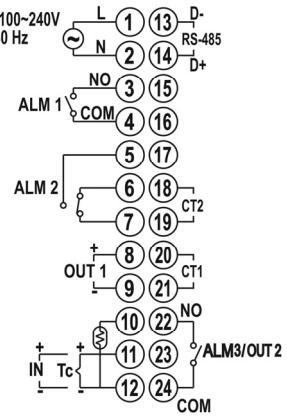

DT340RA-0

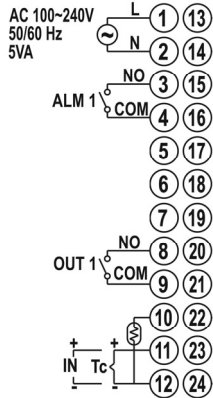

DT340RA; DT360RA

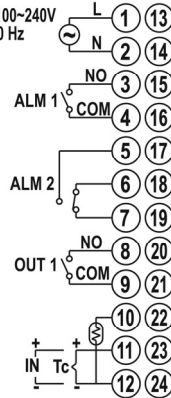

DT340RA-R112; DT360RA-R112

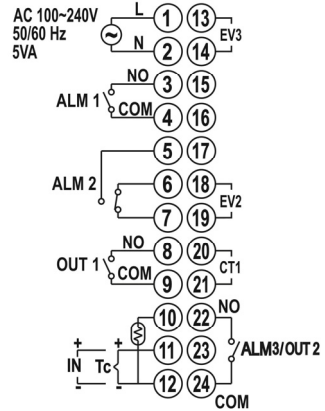

DT340VA-0; DT340CA-0

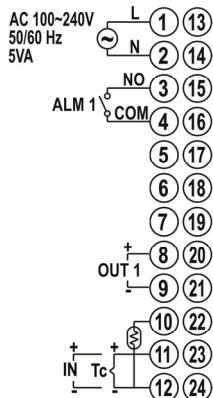

**DT340VA-0003; DT360VA-0003;
DT340CA-0003; DT360CA-0003;
DT340LA-0003.....**

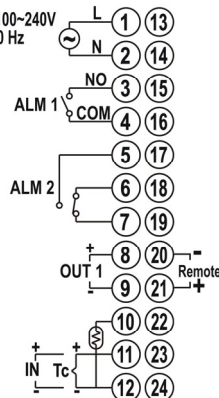

**DT340VA-0030; DT360VA-0030;
DT340CA-0030; DT360CA-0030;
DT340LA-0030.....**

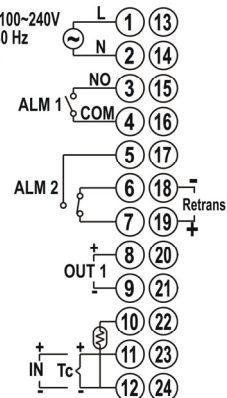

**DT340VA-0200; DT360VA-0200;
DT340CA-0200; DT360CA-0200;
DT340LA-0200.....**

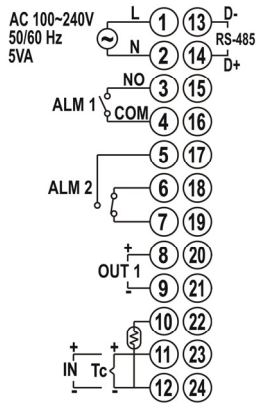

**DT340VA; DT340CA; DT340LA;
DT360VA; DT360CA.....**

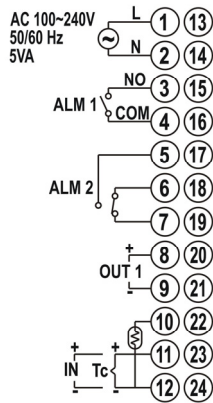

**DT340VA-R011; DT360VA-R011;
DT340CA-R011; DT360CA-R011;
DT340LA-R011.....**

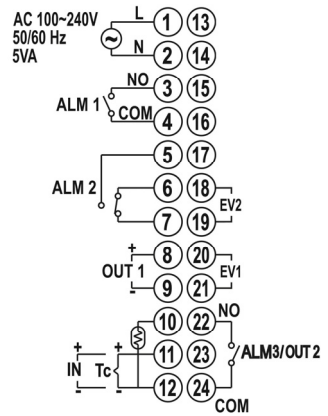

**DT340VA-R200; DT360VA-R200;
DT340CA-R200; DT360CA-R200;
DT340LA-R200.....**

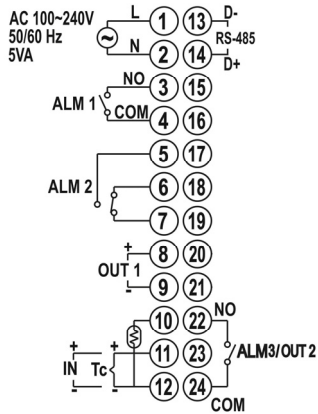

**DT340VA-R211; DT360VA-R211;
DT340CA-R211; DT360CA-R211;
DT340LA-R211.....**

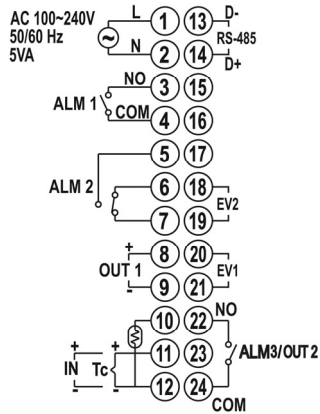

**DT340VA-V231; DT360VA-V231;
DT340CA-C231; DT360CA-C231;
DT340LA-L231.....**

